



Getting Started with PCB Design

Summary

Tutorial
TU0117 (v2.3) May 21, 2008

This introductory tutorial is designed to give you an overview of how to create a schematic, update the design information to a PCB document, route the PCB and generate manufacturing output files. It also investigates the concept of projects and integrated libraries and provides a summary of the 3D PCB environment.

Welcome to the world of Altium Designer – a complete electronic product development environment. This tutorial will get you started with creating a PCB project based on an astable multivibrator design.

 If you are new to Altium Designer then you might like read the guide [Welcome to the Altium Designer Environment](#) for an explanation of the interface, information on how to use panels and managing design documents.

Creating a New PCB Project

A project in Altium Designer consists of links to all documents and setups related to a design. A project file, eg. `xxx.PrjPCB`, is an ASCII text file that lists which documents are in the project and related output setups, eg. for printing and CAM. Documents that are not associated with a project are called 'free documents'. Links to schematic sheets and a target output, eg. PCB, FPGA, embedded (VHDL) or library package, are added to a project. Once the project is compiled, design verification, synchronization and comparison can take place. Any changes to the original schematics or PCB, for example, are updated in the project when compiled.

The process of creating a new project is the same for all project types. We will use the PCB project as an example. We will create the project file first and then create the blank schematic sheet to add the new empty project. Later in this tutorial we will create a blank PCB and add it to the project as well.

To start the tutorial, create a new PCB project:

1. Select **File » New » Project » PCB Project** from the menus, or click on **Blank Project (PCB)** in the **New** section of the **Files** panel. If this panel is not displayed, select **Files** from the **System** button at the bottom right of the main design window.

Alternatively, you could select **Printed Circuit Board Design** in the **Pick a Task** section of the Altium Designer Home Page (**View » Home**) and then click on **New Blank PCB Project**.

2. The **Projects** panel displays. The new project file, `PCB_Project1.PrjPCB`, is listed here with no documents added.
3. Rename the new project file (with a `.PrjPCB` extension) by selecting **File » Save Project As**. Navigate to a location where you would like to store the project on your hard disk, type the name `Multivibrator.PrjPCB` in the **File Name** field and click on **Save**.

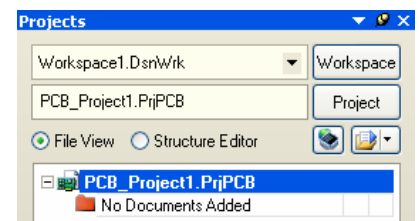

Next we will create a schematic to add to the empty project file. This schematic will be for an astable multivibrator circuit.

Creating a New Schematic Sheet

Create a new schematic sheet by completing the following steps:

1. Select **File » New » Schematic**, or click on **Schematic Sheet** in the **New** section of the **Files** panel. A blank schematic sheet named `Sheet1.SchDoc` displays in the design window and the schematic document is automatically added (linked) to the project. The schematic sheet is now listed under **Source Documents** beneath the project name in the **Projects** tab.

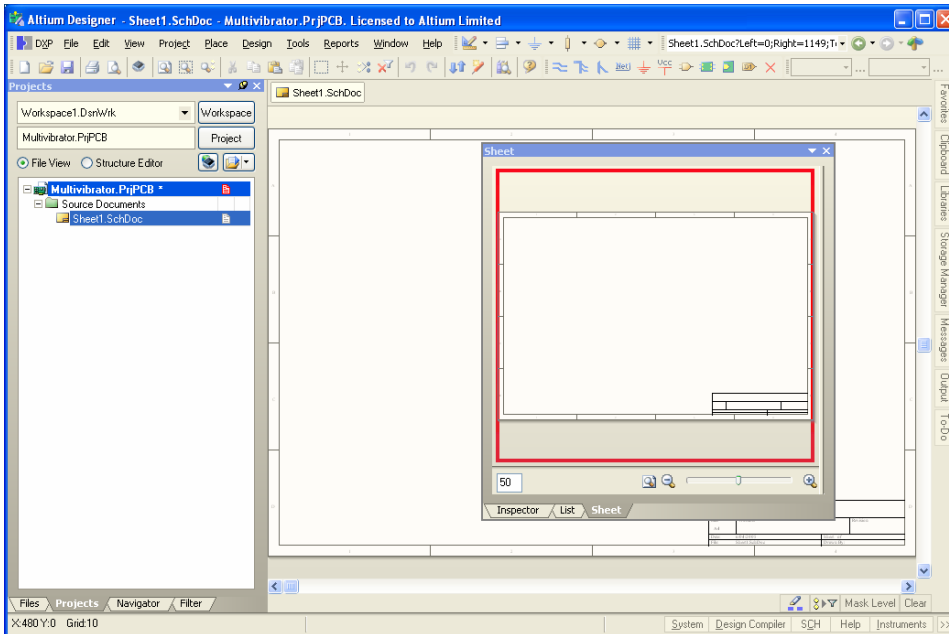

2. Rename the new schematic file (with a `.SchDoc` extension) by selecting **File » Save As**. Navigate to a location where you would like to store the schematic on your hard disk, type the name `Multivibrator.SchDoc` in the **File Name** field and click on **Save**.

When the blank schematic sheet opens you will notice that the workspace changes. The main toolbar includes a range of new buttons, new toolbars are visible, the menu bar includes new items and the **Sheet** panel is displayed. You are now in the Schematic Editor.

You can customize many aspects of the workspace. For example, you can reposition the panels and toolbars or customize the menu and toolbar commands.

Now we can add our blank schematic to the project before proceeding with the design capture.

Adding Schematic Sheets to a Project

If the schematic sheets you want to add to a project file have been opened as Free Documents, right-click on the project name in the **Projects** panel and select **Add Existing to Project**. Select the free documents name(s) and click **Open**. Alternatively, you could drag-and-drop the free document into the project documents list in the **Projects** panel. The schematic sheet is now listed under **Source Documents** beneath the project name in the **Projects** tab and is linked to the project file.

Setting the Schematic Options

The first thing to do before you start drawing your circuit is to set up the appropriate document options. Complete the following steps.

1. From the menus, choose **Design » Document Options** and the *Document Options* dialog will open. For this tutorial, the only change we need to make here is to set the sheet size to standard A4 format. In the **Sheet Options** tab, find the **Standard Styles** field. Click the arrow next to the entry to see a list of sheet styles.
2. Select the **A4** style and click **OK** to close the dialog and update the sheet size.
3. To make the document fill the viewing area again, select **View » Fit Document**.

In Altium Designer, you can activate any menu by pressing the menu hotkey (the underlined letter in the menu name). Any subsequent menu items will also have hot keys that you can use to activate the item.

For example, the shortcut for selecting the **View » Fit Document** menu item is to press the **V** key followed by the **D** key. Many submenus, such as the **Edit » DeSelect** menu, can be called directly. To activate the **Edit » DeSelect » All on Current Document** menu item, you need only press the **X** key (to call up the **DeSelect** menu directly) followed by the **S** key.

Next we will set the general schematic preferences.

1. Select **Tools » Schematic Preferences** [shortcut: **T, P**] to open the schematic *Preferences* dialog. This dialog allows you to set global preferences that will apply to all schematic sheets you work on.
2. Click on **Schematic – Default Primitives** in the selection tree (left side of the dialog) to make it the active page and enable the **Permanent** option. Click **OK** to close the dialog.
3. Before you start capturing your schematic, save this schematic sheet, so select **File » Save** [shortcut: **F, S**].

Altium Designer has a multilevel Undo, allowing you to undo any number of previous actions. The maximum number of Undo steps is user-configurable and limited only by the available memory on your computer.

You can save any schematic sheet as a document template (.schematic) allowing you to include special information such as a custom company title block and logo.

Drawing the Schematic

You are now ready to begin capturing (drawing) the schematic. For this tutorial, we will use the circuit shown in Figure 1. This circuit uses two 2N3904 transistors configured as a self-running astable multivibrator.

Locating the Component and Loading the Libraries

To manage the thousands of schematic symbols included with Altium Designer, the Schematic Editor provides powerful library search features. Although the components we require are in the default installed libraries, it is useful to know how to search through the libraries to find components. Work through the following steps to locate and add the libraries you will need for the tutorial circuit.

First we will search for the transistors, both of which are type 2N3904.

1. Click on the **Libraries** tab to display the **Libraries** panel.
2. Press the **Search** button in the **Libraries** panel, or select **Tools » Find Component**, to open the *Libraries Search* dialog.
3. Ensure that **Search in** dropdown in the **Options** region is set to **Components** for this example. There are other options for library searching using different criteria.
4. Ensure that the **Scope** is set to **Libraries on Path** and that the **Path** field contains the correct path to your libraries. If you accepted the default directories during installation, the path should be the `Library` folder of your Altium Designer installation. Click on the folder icon to browse to the library folder. Ensure that the **Include Subdirectories** box is not selected (not ticked) for this example.
5. We want to search for all references to 3904, so type `*3904*` in the query section at the top of the *Libraries Search* dialog. The `*` symbol is a wildcard used to take into account the different prefixes and suffixes used by different manufacturers.
6. Click the **Search** button to begin the search. The Query Results are displayed in the **Libraries** panel as the search takes place.
7. Click on the component name 2N3904 found in the `Miscellaneous Devices.IntLib` library to select it. This library has symbols for all the available simulation-ready BJT transistors.
8. If you choose a component that resided in a library that was not currently installed, you would be asked to confirm the installation of that library before you could place the component on your schematic. Since the `Miscellaneous Devices` library we need is already installed by default, the component is ready to place.

The added libraries will appear in the drop down list at the top of the **Libraries** panel. As you click on a library name in the upper list, the components in that library are listed below. The component filter in the panel can then be used to quickly locate a component within a library.

Placing the Components on Your Schematic

The first components we will place on the schematic are the two transistors, Q1 and Q2. For the general layout of the circuit, refer to the schematic drawing shown in Figure 1.

1. Select **View » Fit Document** [shortcut: **V, D**] to ensure your schematic sheet takes up the full window.
2. Make sure the **Libraries** panel is displayed by clicking on the **Libraries** tab.
3. Q1 and Q2 are BJT transistors, so select the `Miscellaneous Devices.IntLib` library from the **Libraries** drop-down list at the top of the **Libraries** panel to make it the active library.

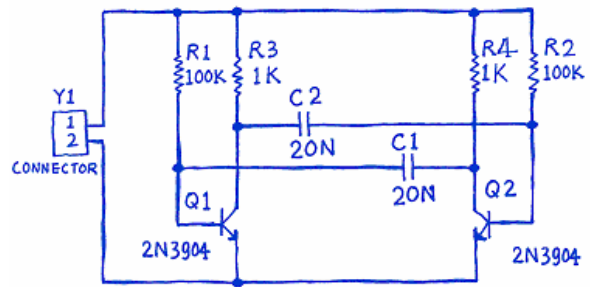
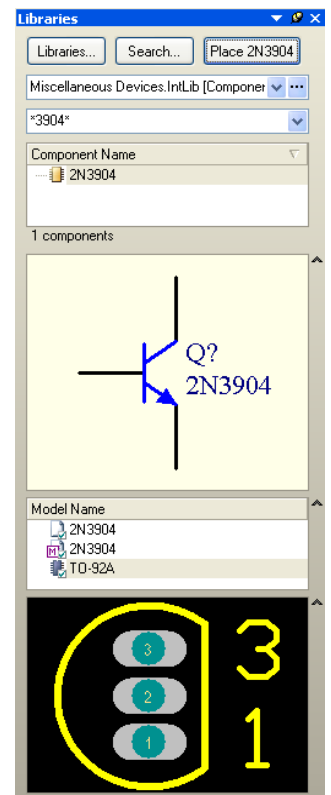
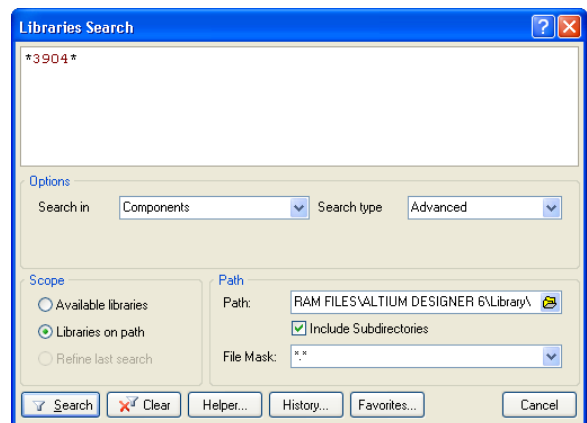
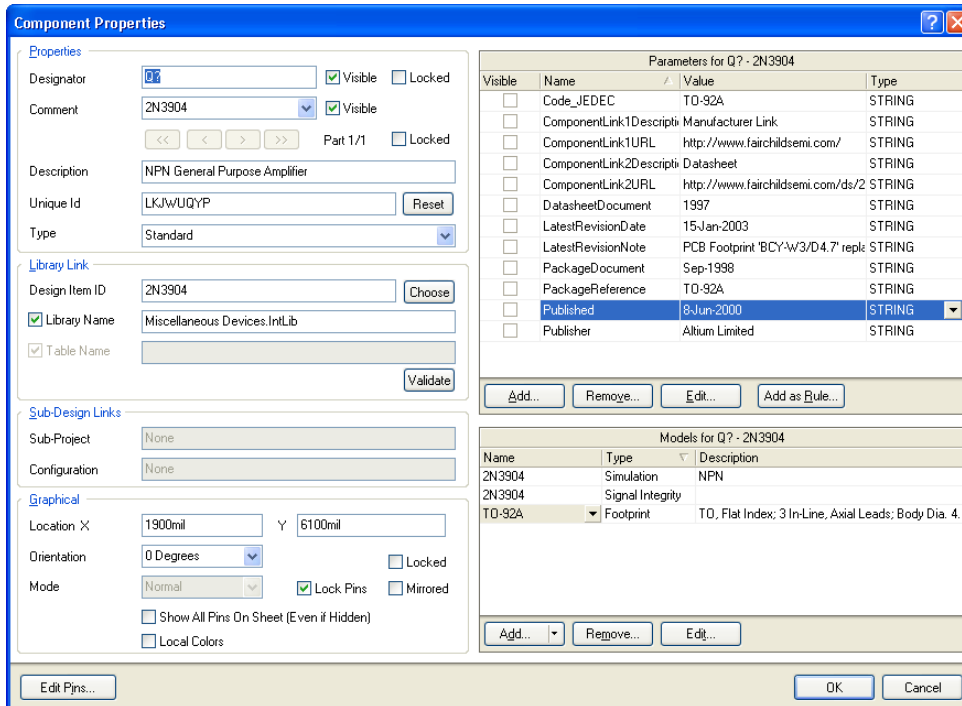

Figure 1. An astable multivibrator.



- Use the filter to quickly locate the component you need. The default wildcard (*) will list all components found in the library. Set the filter by typing *3904* in the filter field below the Library name. A list of components which have the text "3904" as part of their Component Name field will be displayed.
- Click on the **2N3904** entry in the list to select it, then click the **Place** button. Alternatively, just double-click on the component name. The cursor will change to a cross hair and you will have an outlined version of the transistor "floating" on your cursor. You are now in part placement mode. If you move the cursor around, the transistor outline will move with it.
- Before placing the part on the schematic, first edit its properties. While the transistor is floating on the cursor, press the **TAB** key. This opens the *Component Properties* dialog for the component. We will now set up the dialog options to appear as below.



The link between the schematic component and the PCB component is the footprint. The footprint specified in the schematic is loaded from the PCB library when you load the netlist. Double-click on a schematic component to specify the footprint.

- In the **Properties** section of the dialog, set the value for the first component designator by typing Q1 in the **Designator** field.
- Next we will check the footprint that will be used to represent the component in the PCB. For this tutorial, we have used integrated libraries which mean that the recommended models for footprints and circuit simulation are already included. Make sure that footprint name TO-92A is included in the **Models** list. Leave all other fields at their default values and click **OK** to close the dialog.

You are now ready to place the part.

- Move the cursor (with the transistor symbol attached) to position the transistor a little left of the middle of the sheet. Once you are happy with the transistor's position, click or press **ENTER** to place the transistor onto the schematic.
- Move the cursor and you will find that a copy of the transistor has been placed on the schematic sheet, but you are still in part placement mode with the part outline floating on the cursor. This feature of Altium Designer allows you to place multiple parts of the same type. So let's now place the second transistor. This transistor is the same as the previous one, so there is no need to edit its attributes before we place it. Altium Designer will automatically increment a component's designator when you place a series of parts. In this case, the next transistor we place will automatically be designated Q2.
- If you refer to the schematic diagram (Figure 1) you will notice that Q2 is drawn as a mirror of Q1. To flip the orientation of the transistor that is floating on the cursor, press the **X** key. This flips the component horizontally.
- Move the cursor to position the part to the right of Q1. To position the component more accurately, press the **PAGE UP** key twice to zoom in two steps. You should now be able to see the grid lines.

When you are in any editing or placement mode (a cross hair cursor is active), moving the cursor to the edge of the document window will automatically pan the document.

If you accidentally pan too far while you are wiring up your circuit, press V, F (View » Fit All Objects) to redraw the schematic window, showing all placed objects. This can be done even when you are in the middle of placing an object.

Use the following keys to manipulate the part floating on the cursor:

- Y flips the part vertically
- X flips the part horizontally
- Spacebar rotates the part by 90° anti-clockwise.

Getting Started with PCB Design

- Once you have positioned the part, click or press **ENTER** to place Q2. Once again a copy of the transistor you are “holding” will be placed on the schematic, and the next transistor will be floating on the cursor ready to be placed.
- Since we have now placed all the transistors, we will exit part placement mode by clicking the right mouse button or pressing the **ESC** key. The cursor will revert back to a standard arrow.

Next we will place the four resistors.

- In the **Libraries** panel, make sure the `Miscellaneous Devices.IntLib` library is active.
- Set the filter by typing `res1` in the filter field below the Library name.
- Click on **Res1** in the components list to select it, then click the **Place** button. You will now have a resistor symbol floating on the cursor.
- Press the **TAB** key to edit the resistor's attributes. In the **Properties** section of the dialog, set the value for the first component designator by typing `R1` in the **Designator** field.
- Make sure that footprint name `AXIAL-0.3` is included in the **Models** list.
- The contents of **Comment** field of the schematic component maps to the **Comment** field of the PCB component, typically you would enter the value or the resistor here. Enter a value of `100k` into the **Comment** field for R1.

To edit the attributes of an object placed on the schematic, double-click the object to open its *Component Properties* dialog.

Components being simulated may have a number of simulation properties that can be defined (eg, a resistor has 1, a BJT has 5, and a MOSFET has 13), these properties are defined by using Parameters. If you wanted to simulate this circuit then the resistor value must be defined as a Parameter, whose name is Value and whose value is the resistance.

If the circuit being captured is for both simulation and PCB layout, rather than enter the value twice (in the parameter called Value and then in the Comment field), Altium Designer supports 'indirection', a feature that maps any parameter's string into the Comment field. If you click to display the Comment field dropdown list you will see that the software has automatically built a list of all current parameters, in case you want to map the value of one of them into the Comment field.

- Since you will not be simulating ensure that the **Visible** option for the **Value** parameter is disabled.
- Press the **SPACEBAR** to rotate the resistor by 90° so it is in the correct orientation.
- Position the resistor above the base of Q1 (refer to the schematic diagram in Figure 1) and click or press **ENTER** to place the part. Don't worry about making the resistor connect to the transistor just yet. We will wire up all the parts later.
- Next place the other 100k resistor R2 above the base of Q2. The designator will automatically increment when you place the second resistor.
- The remaining two resistors, R3 and R4, have a value of 1k, so press the **TAB** key to call up the *Component Properties* dialog, enter 1k into the **Comment**, and confirm that the **Visible** option for the **Value** parameter is disabled. Click **OK** to close the dialog.
- Position and place R3 and R4 as shown in the schematic diagram in Figure 1. Right-click or press **ESC** to exit part placement mode.

Now place the two capacitors.

- The capacitor part is also in the `Miscellaneous Devices.IntLib` library, which should already be selected in the **Libraries** panel.
- Type `cap` in the component's filter field in the **Libraries** panel.
- Click on **CAP** in the components list to select it, then click the **Place** button. You will now have a capacitor symbol floating on the cursor.
- Press the **TAB** key to edit the capacitor's attributes. In the *Component Properties* dialog set the **Designator** to `C1`, the **Comment** to `20n`, disable the **Visible** option for the **Value** parameter, and check the PCB footprint model `RAD-0.3` is selected in the **Models** list. Click **OK**.

To reposition any object, place the cursor directly over the object, click-and-hold the left mouse button, drag the object to a new position and then release the mouse button.

As with the resistor, if you wanted to simulate this circuit you would need a **Value** parameter with the value of `20n`, in this case you would define the capacitance in the **Value** parameter and then use the indirection feature to map the contents of the value parameter into the Comment field. Since you will not be simulating ensure that the **Visible** option for the **Value** parameter is disabled.

- Position and place the two capacitors in the same way that you placed the previous parts.
- Right-click or press **ESC** to exit placement mode.

The last component to be placed is the connector, located in `Miscellaneous Connectors.IntLib`.

- Select `Miscellaneous Connectors.IntLib` from the Libraries list in the **Libraries** panel. The connector we want is a two-pin socket, so set the filter to `*2*`.

2. Select **Header 2** from the parts list and click the **Place** button. Press **TAB** to edit the attributes and set **Designator** to Y1 and check the PCB footprint model is HDR1X2. No **Value** parameter is required as you would replace this component with a power source when simulating the circuit. Click **OK** to close the dialog.
3. Before placing the connector, press **X** to flip it horizontally so that it is in the correct orientation. Click to place the connector on the schematic.
4. Right-click or press **ESC** to exit part placement mode.
5. Save your schematic by selecting **File » Save** from the menus [shortcut: **F, S**].

You have now placed all the components. Note that the components in Figure 2 are spaced so that there is plenty of room to wire to each component pin. This is important because you can not place a wire across the bottom of a pin to get to a pin beyond it. If you do, both pins will connect to the wire.

If you need to move a component, click-and-hold on the body of the component, then drag the mouse to reposition it.

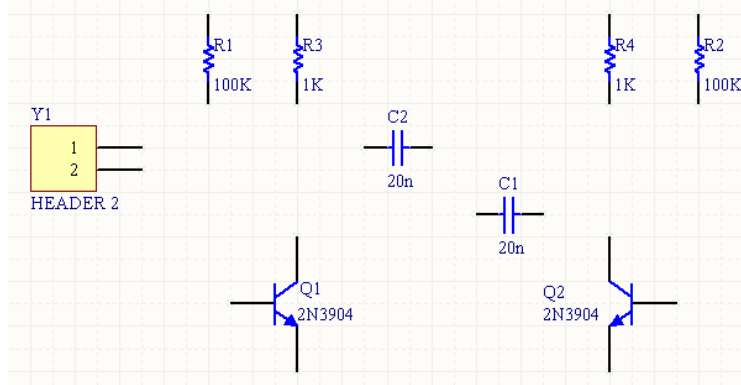

Figure 2. Schematic with all parts placed.

You can re-position a group of selected schematic objects using the arrow keys. The movement of selected objects are set according to the current Snap Grid setting in the Document Options dialog (Document » Options [shortcut: D,O]). You can use this dialog to change the Snap Grid Value. This Grid value also appears on the Status bar of Altium Designer.

The Schematic – Grids page of the Preferences dialog (Tools » Schematic Preferences [shortcut: T, P]) can also be used to set imperial and metric grid presets. Use the G shortcut to cycle through different snap grid setting values. You can also use the View » Grids submenu or the Grids right-click menu.

Selected objects can be 'nugged' by small amounts (by the current snap grid value) by pressing the arrow keys while holding down the CTRL key.

Selected objects can also be 'nugged' by large amounts (the snap grid value by a factor of 10) by pressing the arrow keys while holding down the CTRL and SHIFT keys together.

Wiring up the Circuit

Wiring is the process of creating connectivity between the various components of your circuit. To wire up your schematic, refer to the diagram in Figure 1 and complete the following steps.

1. To make sure you have a good view of the schematic sheet, use the **PAGE UP** key to zoom in or **PAGE DOWN** to zoom out. Also try holding down the **CTRL** key and using the mouse wheel to zoom or holding the mouse wheel down and dragging the mouse up to zoom in or down to zoom out.
2. Firstly wire the resistor R1 to the base of transistor Q1 in the following manner. Select **Place » Wire** [shortcut: **P, W**] from the menus or click on the **Wire** tool from the **Wiring** toolbar to enter the wire placement mode. The cursor will change to a crosshair.
3. Position the cursor over the bottom end of R1. When you are in the right position, a red connection marker (large asterisk) will appear at the cursor location. This indicates that the cursor is over an electrical connection point on the component.
4. Click or press **ENTER** to anchor the first wire point. Move the cursor and you will see a wire extend from the cursor position back to the anchor point.
5. Position the cursor so that it is below R1 and level with the base of Q1. Click or press **ENTER** to anchor the wire at this point. The wire between the first and second anchor points will be placed.
6. Position the cursor over the base of Q1 until you see the cursor change to a red connection marker. Click or press **ENTER** to connect the wire to the base of Q1.
7. Note that the cursor remains a cross hair, indicating that you are ready to place another wire. To exit placement mode completely and go back to the arrow cursor, you would right-click or press **ESC** again – but don't do this just now.
8. We will now wire C1 to Q1 and R1. Position the cursor over the left connection point of C1 and click or press **ENTER** to start a new wire. Move the cursor horizontally till it is directly over the wire connecting the base of Q1 to R1. A connection marker

To graphically edit the shape of a wire, or any other graphical object once it has been placed, position the arrow cursor over it and click once.

Whenever a wire runs across the connection point of a component, or is terminated on another wire, Altium Designer will automatically create a junction.

When placing wires, keep in mind the following points:

- click or press **ENTER** to anchor the wire at the cursor position;
- press **BACKSPACE** to remove the last anchor point;
- after placing the last segment of a wire, right-click or press **ESC** to end the wire placement. The cursor will remain as a cross hair and you can begin placing another wire.
- Right-click again or press **ESC** to exit wire placement mode.

Getting Started with PCB Design

will appear. Click or press **ENTER** to place the wire segment, then right-click or press **ESC** to indicate that you have finished placing the wire. Note how the two wires are automatically connected.

9. Wire up the rest of your circuit, as shown in Figure 3.

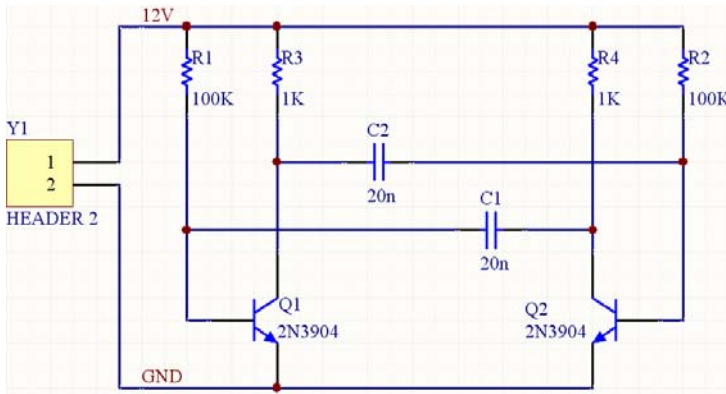

A wire that crosses the end of a pin will connect to that pin, even if you delete the junction. Check that your circuit looks like Figure 3 before proceeding.

Figure 3. The fully wired schematic.

10. When you have finished placing all the wires, right-click or press **ESC** to exit placement mode. The cursor will revert to an arrow.

11. If you wish to move any placed components and drag any connected wires with it, hold down the **CTRL** key while moving the component, or select **Move » Drag**.

Nets and Net Labels

Each set of component pins that you have connected to each other now form what is referred to as a *net*. For example, one net includes the base of Q1, one pin of R1 and one pin of C1.

To make it easy to identify important nets in the design, you can add *net labels*. To place net labels on the two power nets:

1. Select **Place » Net Label** [shortcut: **P, N**]. A dotted box will appear floating on the cursor.
2. To edit the net label before it is placed, press the **TAB** key to display the *Net Label* dialog.
3. Type **12V** in the **Net** field, then click **OK** to close the dialog.
4. Place the net label so that the bottom left of the net label touches the upper most wire on the schematic. The cursor will change to a red cross when the net label touches the wire. If the cross is light gray, it means you are trying to label a pin instead.
5. After placing the first net label you will still be in net label placement mode, so press the **TAB** key again to edit the second net label before placing it.
6. Type **GND** in the **Net** field, click **OK** to close the dialog and place the net label.
7. Place the net label so that the bottom left of the net label touches the lower most wire on the schematic. Right-click or press **ESC** to exit net label placement mode.
8. Select **File » Save** [shortcut: **F, S**] to save your circuit. Save the project as well.



Congratulations! You have just completed your first schematic capture using Altium Designer.

Before we turn the schematic into a circuit board, let's set up the project options.

Setting Up Project Options

The project options include the error checking parameters, a connectivity matrix, Class Generator, the Comparator setup, ECO generation, output paths and netlist options, Multi-Channel naming formats, Default Print setups, Search Paths and any project parameters you wish to specify. Altium Designer will use these setups when you compile the project.

When a project is compiled, comprehensive design and electrical rules are applied to verify the design. When all errors are resolved, the re-compiled schematic designs are loaded into the target document, eg. a PCB document, by generated ECOs.

The project Comparator allows you to find differences between source and target files and update (synchronize) in both directions.

All project-related operations, such as error checking, comparing documents and ECO generation, are set up in the *Options for Project* dialog (**Project » Project Options**).

Project outputs, such as assembly and fabrication outputs and reports can be set up from the **File** menu options. You can also set up job options in a Job Options file (**File » New » Output Job File**). See [Setting Up the Project Outputs](#) for more information.

1. Select **Project » Project Options**. The *Options for ... Project* dialog opens.
2. Set up any project-related options in this dialog. We will now make some changes to the **Error Reporting**, **Connection Matrix** and **Comparator** tabs.

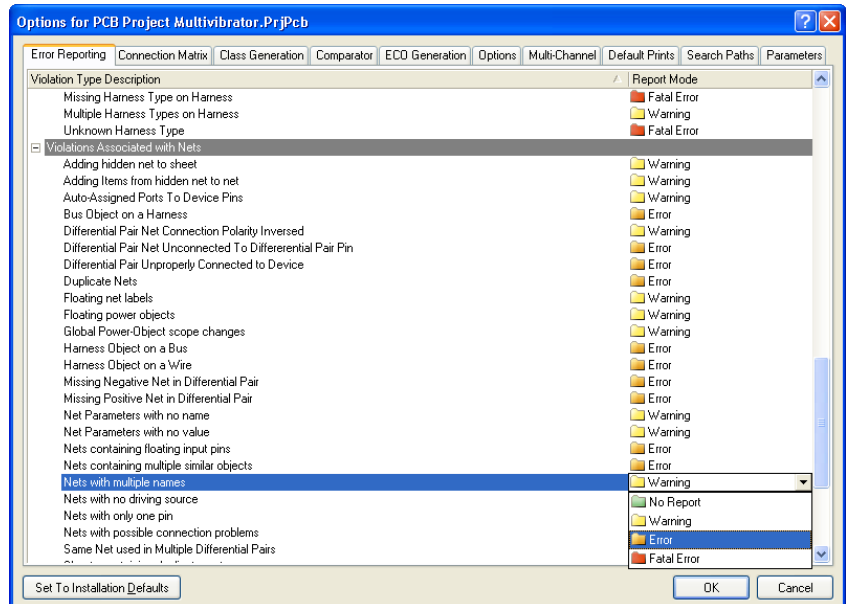

Checking the Electrical Properties of Your Schematic

Schematic diagrams in Altium Designer are more than just simple drawings – they contain electrical connectivity information about the circuit. You can use this connectivity awareness to verify your design. When you compile a project, Altium Designer checks for errors according to the rules set up in the **Error Reporting** and **Connection Matrix** tabs and any violations generated will display in the **Messages** panel.

Setting Up Error Reporting

The **Error Reporting** tab in the *Options for ... Project* dialog is used to set up design drafting checks. The **Report Mode** settings show the level of severity of a violation. If you wish to change a setting, click on a **Report Mode** next to the violation you wish to change and choose the level of severity from the drop-down list. For this tutorial we will use the default settings.

Setting Up the Connection Matrix

The **Connection Matrix** tab (*Options for ... Project* dialog) displays the severity of an error type that is produced when error reporting is run to check electrical connections within the design, i.e. connections between pins, ports and sheet entries. The matrix gives a graphical representation of different types of connection points on a schematic and whether they are allowable or not.

For example, look down the entries on the right side of the matrix diagram and find **Output Pin**. Read across this row of the matrix till you get to the **Open Collector Pin** column. The square where they intersect is orange indicating that an Output Pin connected to an Open Collector Pin on your schematic will generate an error condition when the project is compiled.

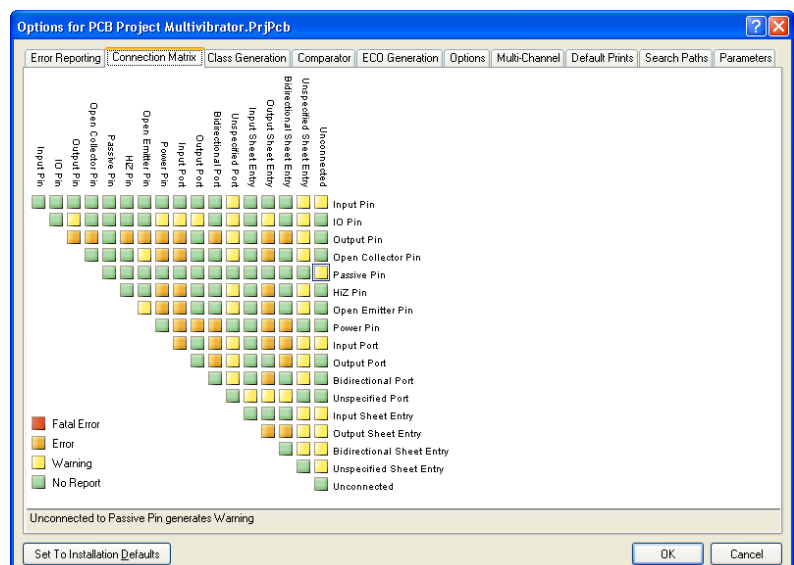

Getting Started with PCB Design

You can set each error type with a separate error level, eg. from no report at all through to a fatal error. Right-click to see the menu options to control the entire matrix.

To make changes to the Connection Matrix:

1. Click on the **Connection Matrix** tab in the *Options for ... Project* dialog.
2. Click on the box that is at the intersection of two types of connection, eg. **Output Sheet Entry** and **Open Collector Pin**.
3. Click until the box changes to the color of the errors as listed in the legend, eg. an orange box indicates that an error will be generated if such a connection is found.

Our circuit contains only Passive Pins (on resistors, capacitors and the connector) and Input Pins (on the transistors). Let's check to see if the connection matrix will detect unconnected passive pins.

1. Look down the row labels to find **Passive Pin**. Look across the column labels to find **Unconnected**. The square where these entries intersect indicates the error condition when a *passive pin* is found to be *unconnected* in the schematic. The default is a green square, which indicates that no report will be generated.
2. Click on this intersection box until it turns yellow, so that a warning will be generated for unconnected passive pins when we compile the project. We will purposely create an instance of this error to check it later in this tutorial.

Setting Up the Comparator

The **Comparator** tab in the *Options for ... Project* dialog sets which differences between files will be reported or ignored when a project is compiled. For this tutorial, we do not need to show differences between some features that refer to hierarchical schematic designs only, such as rooms. Make sure you do not accidentally ignore components when you meant to ignore component classes!

1. Click the **Comparator** tab and find **Changed Room Definitions, Extra Room Definitions and Extra Component Classes** in the **Differences Associated with Components** section.
2. Select **Ignore Differences** from the dropdown list in the **Mode** column to the right of the abovementioned options.

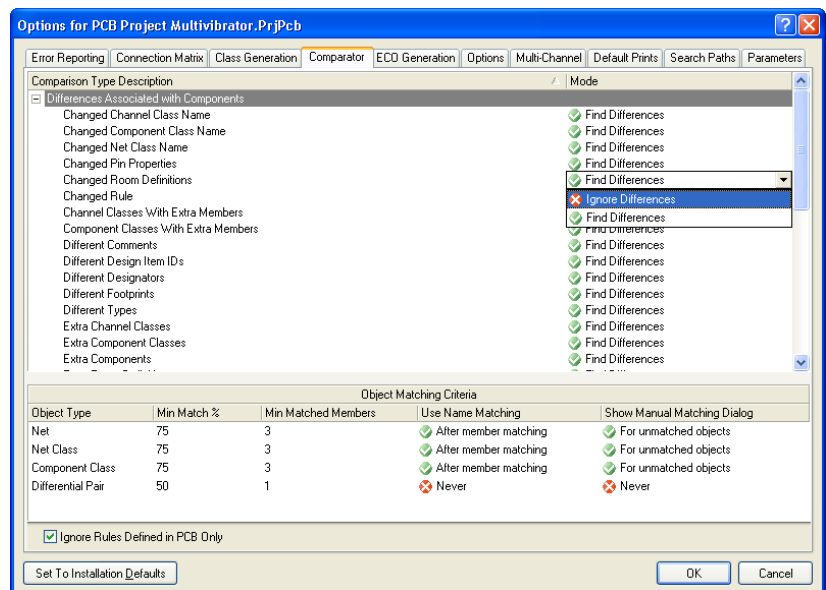

Now we are ready to compile the project and check for any errors.

Compiling the Project

Compiling a project checks for drafting and electrical rules errors in the design documents and puts you into a debugging environment. We have already set up the rules in the **Error Checking** and **Connection Matrix** tabs of the *Options for Project* dialog.

1. To compile our Multivibrator project, select **Project » Compile PCB Project...**
2. When the project is compiled, any errors generated will display in the **Messages** panel. Click on this panel to check for errors (**View » Workspace Panels » System » Messages**). The compiled documents will be listed in the **Navigator** panel, together with a flattened hierarchy, components and nets listed and a connection model that can be browsed.

If your circuit is drawn correctly, the **Messages** panel should not contain any errors. If the report gives errors, check your circuit and ensure all wiring and connections are correct.

We will now deliberately introduce an error into our circuit and recompile the project:

1. Click on the `Multivibrator.SchDoc` tab at the top of the design window to make the schematic sheet the active document.
2. Click in the middle of the wire that connects R1 to the base wire of Q1. Small, square editing handles will appear at each end of the wire and the selection color will display as a dotted line along the wire to indicate that it is selected. Press the **DELETE** key to delete the wire.
3. Recompile the project (**Project » Compile PCB Project**) to check that any errors are found.
The **Messages** panel will display warning messages indicating you have unconnected pins in your circuit. Select **View » Workspace Panels » System » Messages** if the **Messages** panel is not displayed.
4. Double-click on an error or warning in the **Messages** panel and the *Compile Errors* window will display with details of the violation. From this window, you can click on an error and jump to the violating object in a schematic to check or correct the error.

Before we finish this section of the tutorial, let's fix the error in our schematic.

1. Click on the tab of the schematic sheet to make it active.
2. Select **Edit » Undo** from the menus [shortcut: **CTRL + Z**]. The wire you deleted previously should now be restored.
3. To check that the undo was successful, recompile the project (**Project » Compile PCB Project**) to check that no errors are found. The **Messages** panel should show no errors.
4. Select **View » Fit All Objects** [shortcut: **V, F**] from the menus to restore your schematic view and save your error-free schematic.
5. Save the schematic and the project file as well.

If you wish to clear messages from the Messages panel, right-click in the window and select Clear All.

Now we have completed and checked our schematic, it is time to create the PCB.

Creating a New PCB Document

Before you transfer the design from the Schematic Editor to the PCB Editor, you need to create the blank PCB with at least a board outline. The easiest way to create a new PCB design in Altium Designer is to use the **PCB Board Wizard**, which allows you to choose from industry-standard board outlines as well as create your own custom board sizes. At any stage you can use the **Back** button to check or modify previous pages in the wizard.

To create a new PCB using the PCB Wizard, complete the following steps:

1. Create a new PCB by clicking on **PCB Board Wizard** in the **New from Template** section at the bottom of the **Files** panel. If this option is not displayed on the screen, close some of the sections above by clicking on the up arrow icons.
2. The **PCB Board Wizard** opens with an introduction page. Click **Next** to continue.
3. Set the measure units to **Imperial**, i.e. 1000mil = 1 inch.
4. The third page of the wizard allows you to select the board outline you wish to use. For this tutorial we will enter our own board size. Select **Custom** from the list of board outlines and click **Next**.
5. In the next page you enter custom board options. For the tutorial circuit, a 2 x 2 inch board will give us plenty of room. Select **Rectangular** and type 2000 in both the **Width** and **Height** fields. Deselect **Title Block & Scale**, **Legend String** and **Dimension Lines**. Click **Next** to continue.
6. This page allows you to select the number of layers in the board. We will need two signal layers and no power planes. Click **Next** to continue.
7. Choose the via styles used in the design by selecting **Thruhole Vias only** and click **Next**.
8. The next page allows you to set the component/track technology (routing) options. Select the **Through-hole components** option and set the number of tracks between adjacent pads to **One Track**. Click **Next**.
9. The next page allows you to set up some of the design rules for track width and via sizes that apply to your board. Leave the options on this screen set to their defaults. Click **Next**.
10. Click **Finish**. The **PCB Board Wizard** has now collected all the information it needs to create your new board. The PCB Editor will now display a new PCB file named PCB1 . PcbDoc.
11. The PCB document displays with a default sized white sheet and a blank board shape (black area with grid). To turn it off, select **Design » Board Options** and deselect **Display Sheet** in the *Board Options* dialog.

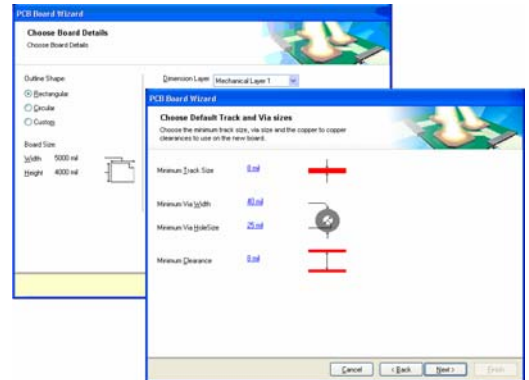

You can add your own border, grid reference and title block from other PCB templates supplied with Altium Designer.

For more information about using board shapes, sheets and templates, refer to the [Preparing the Board for Design Transfer](#) tutorial.

12. Now the sheet has been turned off, display the board shape only by selecting **View » Fit Board** [shortcut: **V, F**].

13. The PCB document is automatically added (linked) to the project and is listed under Source Documents beneath the project name in the **Projects** tab. Rename the new PCB file (with a .PcbDoc extension) by selecting **File » Save As**. Navigate to a location where you would like to store the PCB, type the name Multivibrator.PcbDoc in the **File Name** field and click **Save**.

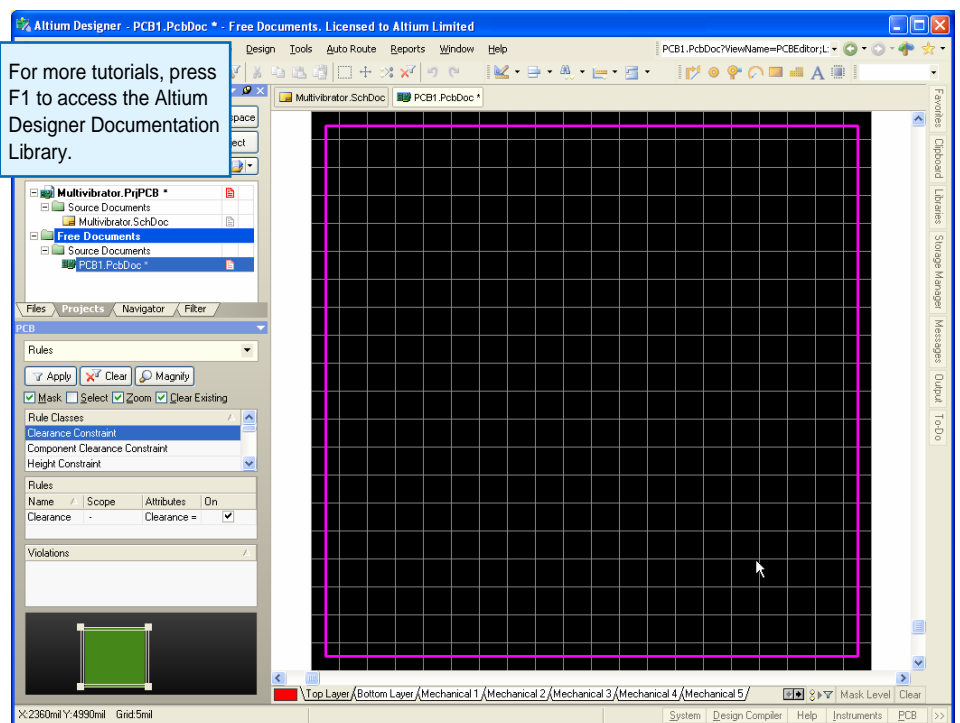

Adding a New PCB to a Project

If the PCB you want to add to a project file has been opened as a Free Document, right-click on the PCB project file in the **Projects** panel and select **Add Existing to Project**. Choose the new PCB file name and click on **Open**. The PCB is now listed under **Source Documents** beneath the project in the **Projects** panel and is linked to the project file. You can also do this by dragging the free document and dropping it on to project file. Save the project file.

Transferring the Design

Before transferring the schematic information to the new blank PCB, make sure all the related libraries for both schematic and PCB are available. Since only the default installed integrated libraries are used in this tutorial, the footprints will already be included. Once the project has been compiled and any errors in the schematic fixed, use the **Update PCB** command to generate ECOs (Engineering Change Orders) that will transfer the schematic information to the target PCB.

Updating the PCB

To send the schematic information to the target PCB in your project:

1. Open the schematic document, `Multivibrator.SchDoc`.
2. Select **Design » Update PCB Document** (`Multivibrator.PcbDoc`). The project compiles and the *Engineering Change Order* dialog displays.
3. Click on **Validate Changes**. If all changes are validated, the green ticks appear in the **Status** list. If the changes are not validated, close the dialog, check the **Messages** panel and clear any errors.
4. Click on **Execute Changes** to send the changes to the PCB. When completed, the **Done** column entries become ticked.
5. Click **Close** and the target PCB opens with components positioned ready for placing on the board. Use the shortcut **V, D** (**View » Document**) if you cannot see the components in your current view.

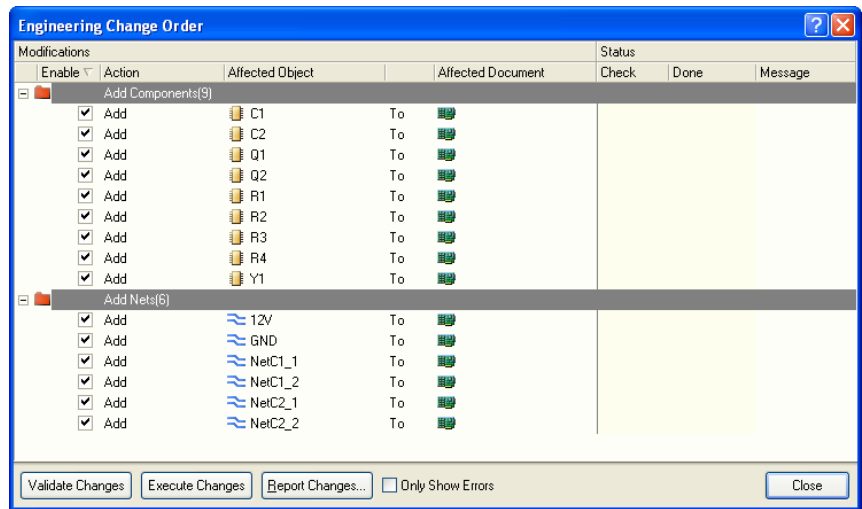

You can create a report of ECOs to print out by clicking the Report Changes button.

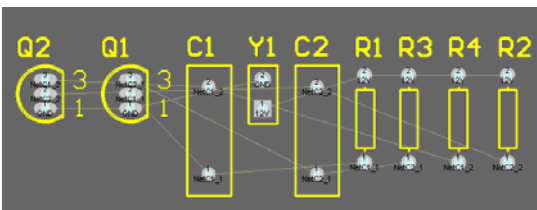

Figure 4. The components next to the board, ready for positioning.

Designing the PCB

Now we can start placing the components on the PCB and routing the board.

Setting Up the PCB Workspace

Before we start positioning the components on the board, we need to set up the PCB workspace, such as the grids, layers and design rules. The PCB Editor workspace is capable of rendering the PCB design in both 2D and 3D modes.

2D mode is a multi-layered environment that is ideal for normal PCB design routines such as placing components, routing and connecting. 3D mode is useful for examining your design both inside and out as a full 3D model (3D mode does not provide the full range of functionality available in 2D mode). You can switch between 2D and 3D modes through **File » Switch To 3D** or **File » Switch To 2D** [shortcut: **2** (2D), **3** (3D)].

Grids

We need to ensure that our placement grid is set correctly before we start positioning the components. All the objects placed in the PCB workspace are aligned on a grid called the *snap grid*. This grid needs to be set to suit the routing technology that you intend to use.

Our tutorial circuit uses standard imperial components that have a minimum pin pitch of 100mil. We will set the snap grid to an even fraction of this, say 50mil or 25mil, so that all component pins will fall on a grid point when placed. Also, the track width and clearance for our board are 12mil and 13mil respectively (the default values used by the **PCB Board Wizard**), allowing a minimum of 25mil between parallel track centers. The most suitable snap grid setting would, therefore, be 25mil.

To set the snap grid, complete the following steps:

1. Select **Design » Board Options** [shortcut: **D, O**] to open the *Board Options* dialog.
2. Set the values of the **Snap Grid** and the **Component Grid** to 25mil using the dropdown lists or typing in the value. Note that this dialog is also used to define the **Electrical Grid**. This grid operates when you place an electrical object; it overrides the snap grid and snaps electrical objects together. Click **OK** to close the dialog.

The PCB Editor supports imperial and metric units. Select **View » Toggle Units** to switch. Many dialogs feature a toggle control  that changes the units of measurement currently used in the dialog.

Let's set some other options that will make positioning components easier.

1. Select **Tools » Preferences** [shortcut: **T, P**] to open the *Preferences* dialog. Click on **PCB Editor – General** in the dialog's selection tree (left side panel) to display the **PCB Editor – General** page. In the **Editing Options** section, make sure the **Snap To Center** option is enabled. This ensures that when you “grab” a component to position it, the cursor is set to the component's reference point.
2. Click on **PCB Editor – Display**. In the **DirectX Options** section of this page, enable the **Use DirectX if possible** option. This will allow us to utilize the latest 3D view mode. Press **OK** to close the *Preferences* dialog.

Note: Altium Designer's 3D view mode requires DirectX 9.0C and Shader Model 3 or later to run as well as a suitable graphics card. If you cannot run DirectX you will be limited to using the legacy 3D viewer.

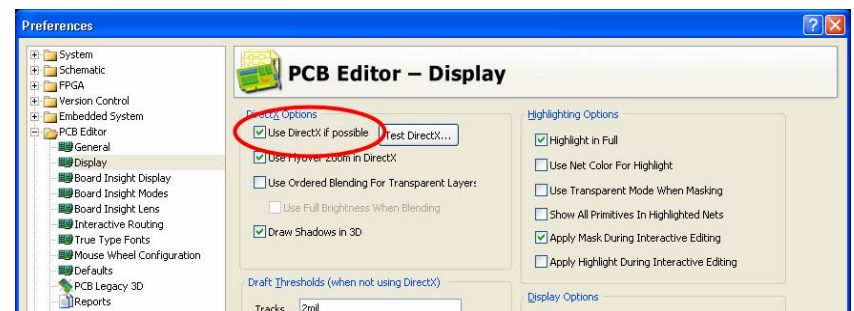
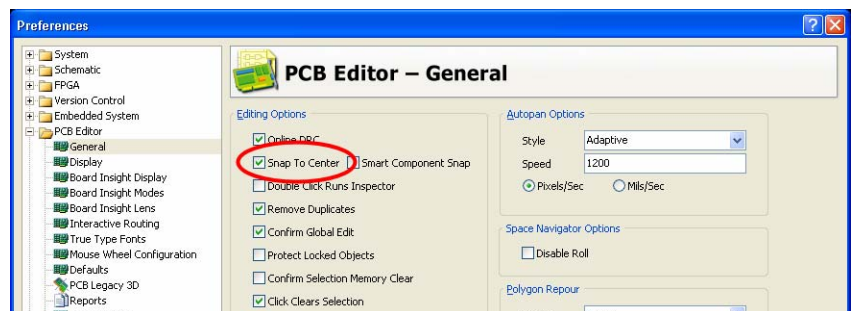

Defining the Layer Stack and Other Non-electrical Layers in a View Configuration

View configurations are settings that control many PCB workspace display options for both 2D and 3D environments and apply to the PCB and PCB Library Editors. The view configuration last used when saving any PCB document is also saved with the file. This enables it to be viewed on another instance of Altium Designer using its associated view configuration. View configurations can also be saved locally and be used and applied at any time to any PCB document. Any PCB files that you open which do not have an associated view configuration are displayed using a system default one.

Note: The *View Configurations* dialog provides access to 2D color settings for layers and other system-based color settings – these are *system settings*, that is, they will apply to all PCB documents and are not part of a view configuration. Color profiles for the 2D workspace can also be created and saved, similarly to view configurations, and can be applied at any time.

Select **Design » Board Layers & Colors** [shortcut: **L**] from the main menu to open the *View Configurations* dialog. This dialog enables you to define, edit, load and save view configurations. It has settings to control which layers to display, how to display common objects such as polygons, pads, tracks, strings etc, displaying net names and reference markers, transparent layers and single layer mode display, 3D surface opacity and colors and 3D body display.

You can apply view configurations using the *View Configurations* dialog or by selecting them directly from the drop-down list on the **PCB Standard** toolbar.



If you look at the bottom of the PCB workspace, you will notice a series of layer tabs, most of the editing actions you perform will be on a particular layer.

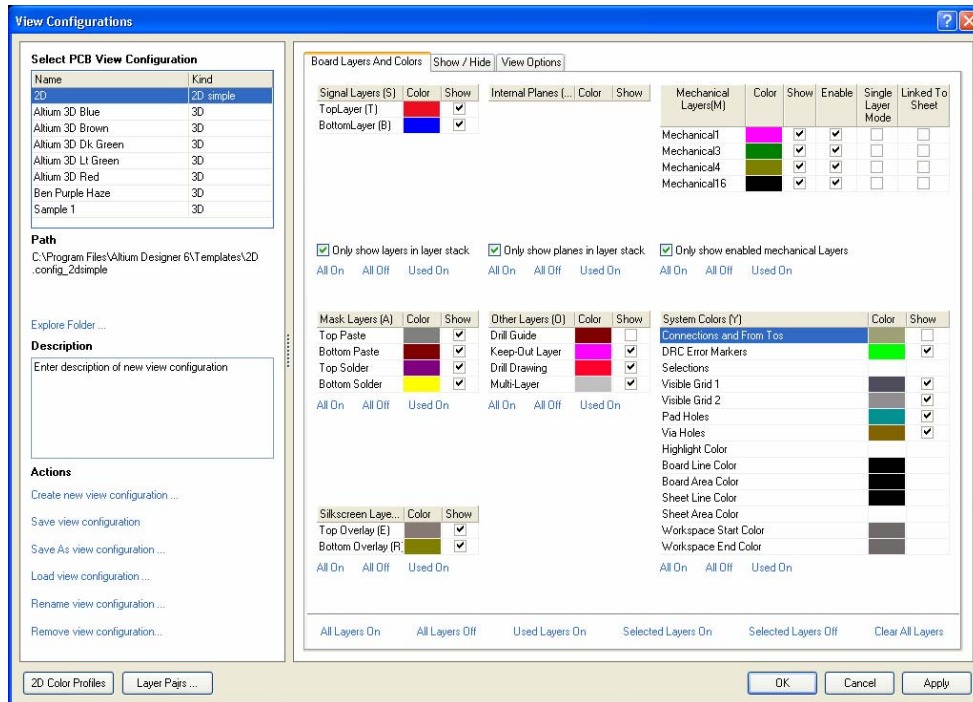

There are three types of layers used in the PCB Editor:

- **Electrical layers** – these include the 32 signal layers and 16 internal plane layers. Electrical layers are added to and removed from the design in the *Layer Stack Manager* dialog, select **Design » Layer Stack Manager** to display it.
- **Mechanical layers** – there are 16 general purpose mechanical layers for defining the board outline, placing dimensions on, including fabrication details on, or any other mechanical details the design requires. These layers can be selectively included in print and Gerber output generation. You can add, remove and name mechanical layers in the *View Configurations* dialog.
- **Special layers** – these include the top and bottom silkscreen layers, the solder and paste mask layers, drill layers, the Keep-Out layer (used to define the electrical boundaries), the multilayer (used for multilayer pads and vias), the connection layer, DRC error layer, grid layers and hole layers.

Let's create a simple 2D view configuration for this tutorial.

1. Select **Design » Board Layers & Colors** [shortcut: **L**] to open the *View Configurations* dialog. The dialog opens with the active configuration selected under the **Select PCB View Configuration**. If you were in 3D mode, click on a 2D configuration.
2. In the **Board Layers And Colors** page, enable the **Only show layers in layer stack** and **Only show enabled mechanical layers** options. These settings will display only the layers in the stack.
3. Click the **Used Layers On** control at the bottom of the page. This will display only layers that are being used. That is, have design elements on them.
4. Click on the color next to **Top Layer** to display the *2D System Colors* dialog and select #7 (yellow) from the **Basic** list of colors. Click **OK** to return to the *View Configurations* dialog.
5. Click on the color next to **Bottom Layer** to display the *2D System Colors* dialog and select #228 (bright green) from the **Basic** colors list. Click **OK** to return to the *View Configurations* dialog.

Getting Started with PCB Design

- Click on the color next to **Top Overlay** to display the *2D System Colors* dialog and select #233 (white) from the **Basic** colors list. Click **OK** to return to the *View Configurations* dialog.
- Make sure the four **Mask** layers and the **Drill Drawing** layer will not display by ensuring that the **Show** option for each layer is disabled.
- In the **Actions** section, click **Save As view configuration** and save the file as `tutorial.config_2dsimple`.
- Click **OK** when you return to the *View Configurations* dialog to apply the changes and close it.

Note: Remember that 2D layer color settings are system-based, affecting all PCB documents, and are not part associated with any view configurations. You can create, edit and save 2D color profiles from the *2D System Colors* dialog.

Layer Stack Manager

The tutorial PCB is a simple design and can be routed as a single-sided or double-sided board. If the design was more complex, you would add more layers through the *Layer Stack Manager* dialog.

- Select **Design » Layer Stack Manager** [shortcut: **D, K**] to display the *Layer Stack Manager* dialog.

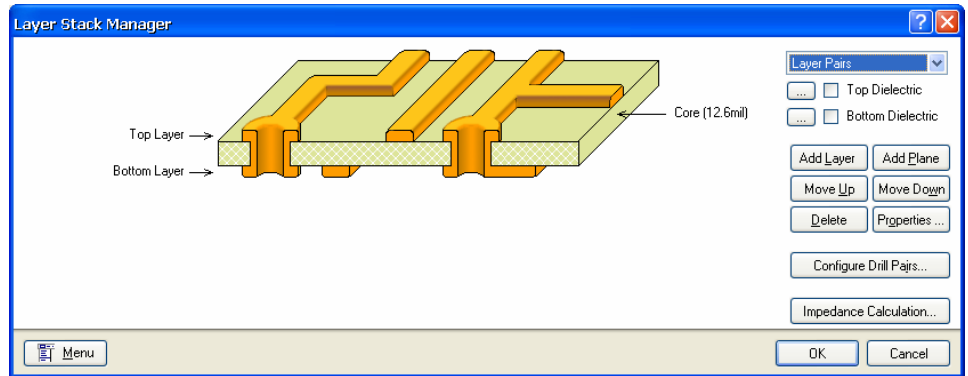

- New layers and planes are added below the currently selected layer. Layer properties, such as copper thickness and dielectric properties are used for signal integrity analysis. Click **OK** to close the dialog.

Setting Up New Design Rules

The PCB Editor is a rules-driven environment, meaning that as you perform actions that change the design, such as placing tracks, moving components, or autorouting the board, Altium Designer monitors each action and checks to see if the design still complies with the design rules. If it does not, then the error is immediately highlighted as a violation. Setting up the design rules before you start working on the board allows you to remain focused on the task of designing, confident in the knowledge that any design errors will immediately be flagged for your attention.

The design rules fall into 10 categories and are further divided into design rule types. The design rules cover electrical, routing, manufacturing, placement and signal integrity requirements.

We will now set up new design rules to specify the width that the power nets must be routed. To set up these rules, complete the following steps:

- With the PCB as the active document, select **Design » Rules** from the menus.

- The *PCB Rules and Constraints Editor* dialog will appear. Each rules category is displayed under the **Design Rules** folder (left hand side) of the dialog. Double-click on the **Routing** category to expand the category and see the related routing rules. Then double-click on **Width** to display the width rules available.

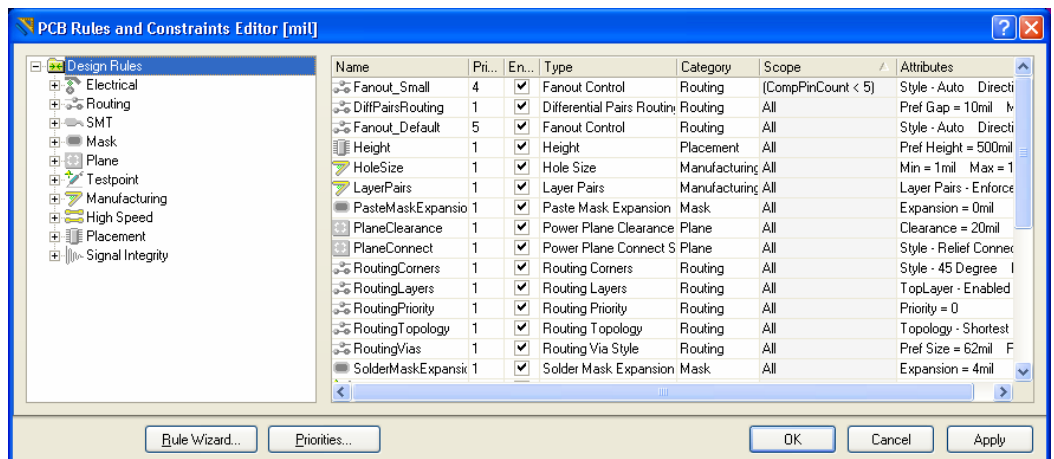

- Click once on each rule to select it. As you click on each rule, the right hand side of the dialog displays the rule's scope (what you want this rule to target) in the top section and the rule's constraints in the bottom section. These rules are either defaults, or have been set up by the **PCB Board Wizard** when the new PCB document was created.
- Click on the **Width** rule to display its scope and constraints. This rule applies to the entire board (**Scope** set to **All**).

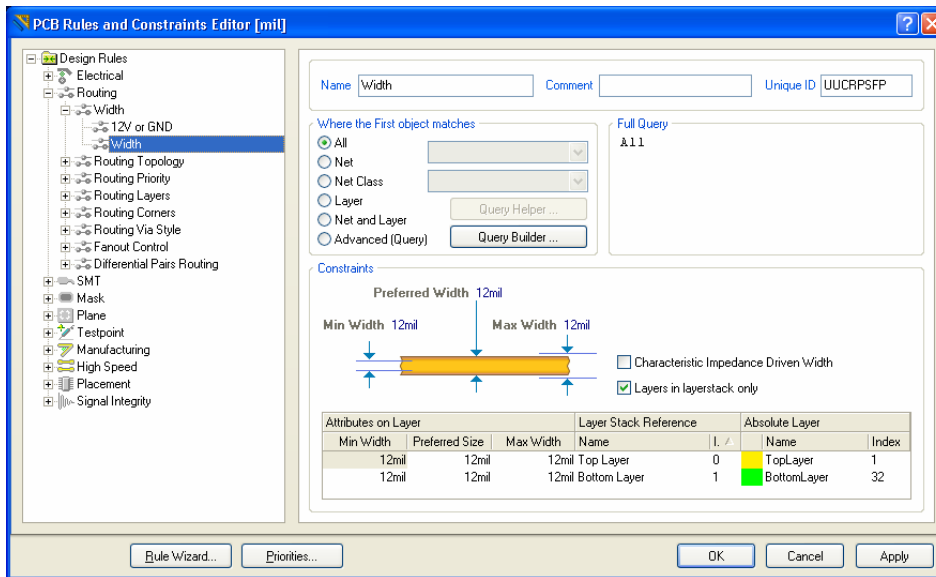

One of the powerful features of Altium Designer's design rule system is that multiple rules of the same type can be defined, each targeting different objects. The exact set of objects that each rule targets is defined by that rule's *scope*. The rule system uses a pre-defined hierarchy to work out which rule to apply to each object.

For example, you could have a width constraint rule for the whole board (meaning all tracks must be this width), a second width constraint rule for the ground net (this rule overrides the previous rule), and a third width constraint rule for a particular connection on the ground net (which overrides both of the previous rules). Rules are displayed in their order of priority.

Currently there is one width constraint rule for your design, which applies to the whole board (width = 12mil). We will now add a new width constraint rule for the 12V and GND nets (width = 25mil). To add new width constraint rules, complete the following steps:

1. With the **Width** category selected in the **Design Rules** folder, right-click and select **New Rule** to add a new width constraint rule set up to target the 12V net only.

A new rule named `width_1` appears. Click on the new rule in the **Design Rules** folder to modify the scope and constraints.

2. Type `12V OR GND` in the **Name** field. The name will refresh in the **Design Rules** region when you click back in it.
3. Next we set the rule's scope using the **Query Builder** but you can always type in the scope directly if you know the correct syntax. If your query is more complicated, select the **Advanced** option, click the **Query Helper** button to use the *Query Helper* dialog.
4. Click on the **Query Builder** button to open the *Building Query from Board* dialog.
5. Click on **Add first condition** and select **Belongs to Net** from the dropdown list. In the Condition Value field, click and select the net **12V** from the list. The **Query Preview** now reads `InNet ('12V')`.
6. Click on **Add another condition** to widen the scope to include the GND net. Select **Belongs to Net** and **GND** as the **Condition Value**.
7. Change the operator by clicking on the operator 'AND' and then select **OR** from the dropdown list. Check that the preview reads `InNet ('12V') OR InNet ('GND')`.
8. Click **OK** to close the *Building Query from Board* dialog. The scope in the **Full Query** section has now been updated with the new query.
9. In the bottom section of the *PCB Rules and Constraints Editor* dialog, change the **Min Width**, **Preferred Width** and **Max Width** fields to 25mil by clicking on the old constraints text (10mil) and typing in the new values. The new rule is now set up and will save when you select another rule or close the dialog.
10. Finally, click to edit the original rule named `width` (**Scope** set to **All**) and confirm that the **Min Width**, **Max Width** and **Preferred Width** fields are all set to 12mil. Click **OK** to close the dialog.

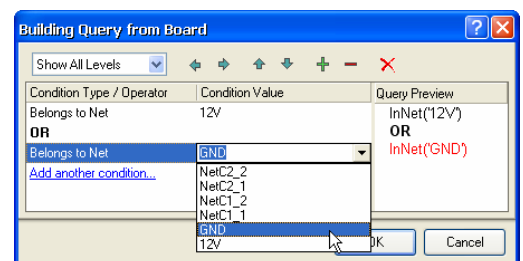

Getting Started with PCB Design

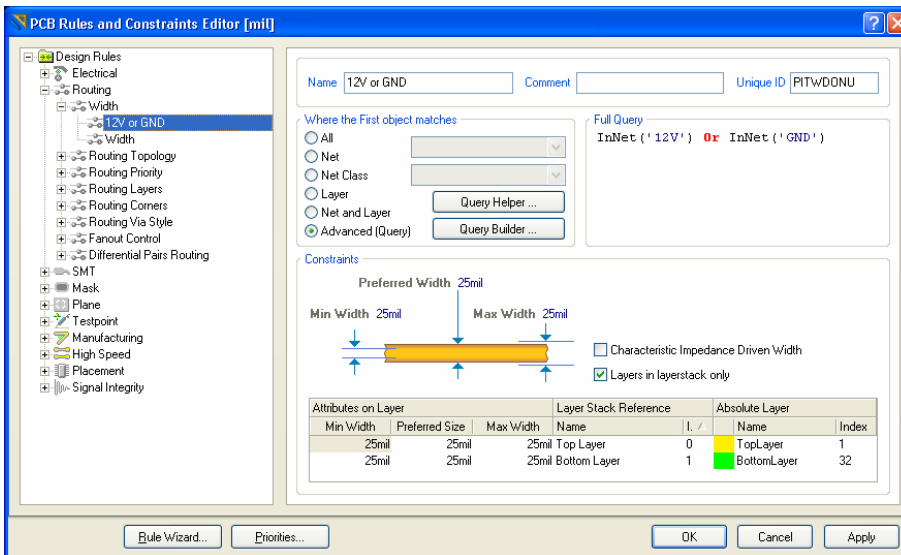

When you route the board manually or using the autorouter, all tracks will be 12mil wide, except the GND and 12V tracks which will be 25mil.

Positioning the Components on the PCB

Now we can start to place the components in their right positions.

1. Press the **V, D** shortcut keys to zoom in on the board and components.
2. To place connector Y1, position the cursor over the middle of the outline of the connector, and click-and-hold the left mouse button. The cursor will change to a cross hair and jump to the reference point for the part. While continuing to hold down the mouse button, move the mouse to drag the component.
3. Position the footprint towards the left-hand side of the board (ensuring that the whole of the component stays within the board boundary), as shown in Figure 5.
4. When the component is in position, release the mouse button to drop it into place. Note how the connection lines drag with the component.
5. Reposition the remaining components, using Figure 5 as a guide. Use the **SPACEBAR** key as necessary to rotate (increments of 90° anti-clockwise) components as you drag them, so that the connection lines are as shown in Figure 5. Don't forget to re-optimize the connection lines as you position each component.

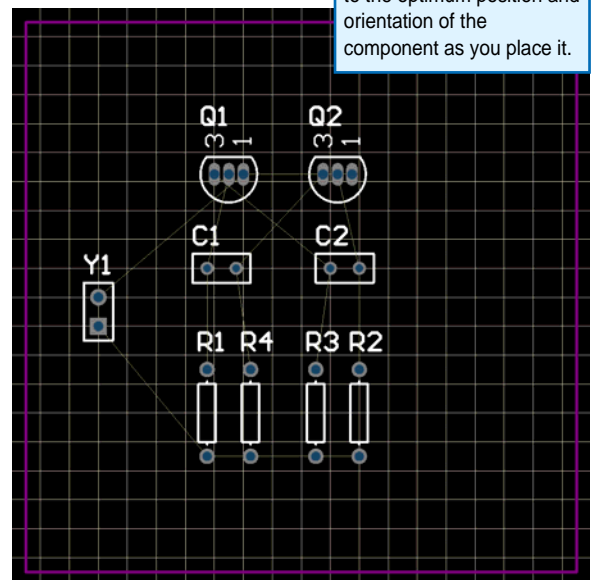
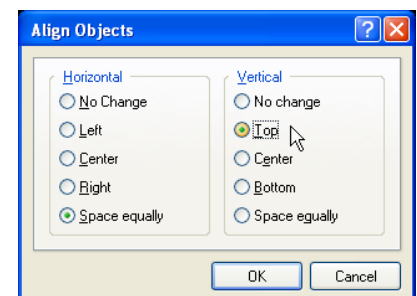

Figure 5. Components placed on the board.

Component text can be repositioned in a similar fashion – click-and-drag the text and press the **SPACEBAR** to rotate it.

Altium Designer also includes powerful interactive placement tools. Let's use these to ensure that the four resistors are correctly aligned and spaced.

1. Holding the **SHIFT** key, click on each of the four resistors to select them, or click and drag the selection box around them. A shaded selection box will display around each of the selected components in the color set for the system color called **Selections**. To change this selection color, select **Design » Board Layers & Colors** [shortcut: **L**].
2. Right-click and select **Align » Align** [shortcut: **A, A**]. In the *Align Objects* dialog, click on **Space Equally** in the Horizontal section and click on **Top** in the Vertical section. The four resistors are now aligned and equally spaced.
3. Click elsewhere in the design window to deselect all the resistors.



Changing a Footprint

Now that we have positioned the footprints, the capacitor footprint appears too big for our requirements! Let's change the capacitor footprint to a smaller one.

1. First we will browse for a new footprint. Click on the **Libraries** panel and select `Miscellaneous Devices.IntLib` from the Libraries list. We want a smaller radial type footprint, so type `rad` in the Filter field. Click on the ... button next to the library name and select only the **Footprints** option to display footprints available in the active library. Click on the Footprint names to see the footprints associated with them. The footprint `RAD-0.1` will do the job.
2. Double-click on the capacitors and change the **Footprint** field to `RAD-0.1` in the *Component* dialog. You can type in the new footprint name, or press the ... button and select a footprint from the *Browse Libraries* dialog. Click **OK** and the new footprints are displayed on the board. Reposition the designators as required. Your board should now look something like Figure 6.

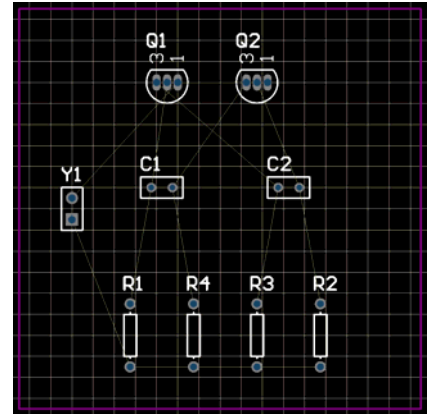

Figure 6. Components placed on the board with new footprints.

With everything positioned, it's time to do some routing!

You can move selected objects on the PCB document using a combination of the CTRL key and arrow keys (vertically or horizontally) or CTRL, SHIFT and arrow keys. The movement of selected objects are set according to the current Snap Grid setting in the *Board Options* dialog (Design » Board Options [shortcut: D, O]). You can use the dialog to set the grid presets. Use the G shortcut to cycle through different snap grid setting values. You can also use the View » Grids submenu or the Snap Grid right-click menu.

Selected objects can be 'nugged' by small amounts (according to the current snap grid value) by pressing the arrow keys while holding down the CTRL key. Selected objects can also be 'nugged' by large amounts (snap grid value by a factor of 10) by pressing the arrow keys while holding down the CTRL and SHIFT keys together.

Manually Routing the Board

Routing is the process of laying tracks and vias on the board to connect the components. Altium Designer makes this job easy by providing sophisticated interactive routing tools as well as the Situs topological autorouter, which optimally routes the whole or part of a board at the touch of a button.

While autorouting provides an easy and powerful way to route a board, there will be situations where you will need exact control over the placement of tracks – or you may want to route the board manually just for the fun of it! In these situations you can manually route part or all of your board. In this section of the tutorial, we will manually route the entire board “single-sided”, with all tracks on the bottom layer. The Interactive Routing tools help maximize routing efficiency and flexibility in an intuitive way, including cursor guidance for track placement, single-click routing of the connection, pushing or walking around obstacles, automatically following existing connections, etc, in accordance with applicable design rules.

We will now place tracks on the bottom layer of the board, using the “ratsnest” connection lines to guide us.

Tracks on a PCB are made from a series of straight segments. Each time there is a change of direction, a new track segment begins. Also, by default Altium Designer constrains tracks to a vertical, horizontal or 45° orientation, allowing you to easily produce professional results. This behavior can be customized to suit your needs, but for this tutorial we will use the default.

1. Enable and show the Bottom Layer by pressing the shortcut key **L** to display the *View Configurations* dialog. Enable the **Show** option next to Bottom Layer in the **Signal Layers** region. Click **OK** and the Bottom Layer tab is displayed along the bottom of the design window.
2. Select **Place » Interactive Routing** from the menus [shortcut: **P, T**] or click the **Interactive Routing** button (🔗). The cursor will change to a crosshair indicating you are in track placement mode.
3. Examine the layer tabs that run along the bottom of the document workspace. The **Top Layer** tab should currently be active. To switch to the bottom layer without dropping out of track placement mode, press the * key on the numeric keypad. This key cycles through the available signal layers. The **Bottom Layer** tab should now be active.
4. Position the cursor over the lower pad on connector Y1. Click or press **ENTER** to anchor the first point of the track.
5. Move the cursor towards the bottom pad of the resistor R1. Note how track segments are displayed in a check pattern, following your cursor path (Figure 7). The check pattern indicates that they have not been committed (placed). If you pull your cursor back along the path, the uncommitted routing 'unwinds' also. You have two choices with routing here:
 - Use **CTRL + Click** to use the *Auto-Complete* function and immediately route the connection (you can use this technique directly on a pad or connection line). The source and target pads must be on the same layer and the routing has to be valid in terms of any obstacles on the board for Auto-Complete to work. On large boards, the Auto-Complete path may not always

Getting Started with PCB Design

be available as the routing path is mapped section by section and complete mapping between source and target pads may not be possible.

- Use **ENTER** or click to commit track segments - you can do this directly on the target pad on R1. This method provides control over the route and still minimizes the number of user actions required .

Uncommitted tracks are shown hatched, committed tracks display in solid color.

- Use either of the above methods to route between the other components on the board. Figure 9 shows a manually routed board.
- Save the design [shortcut: **F, S** or **CTRL + S**].

Altium Designer's Interactive Routing tool features modes that you can use to resolve conflicts with obstacles on the board, such as existing tracks. Cycle through these modes as you interactively route using **SHIFT + R**. The available modes are:

Push - This mode will attempt to move objects (tracks and vias) , which are capable of being repositioned without violation, to accommodate the new routing.

Walkaround - This mode will attempt to find a routing path around existing obstacles without attempting to move them.

Hug & Push - This mode is a combination of Walkaround and Push functionality. It will walkaround obstacles, however, will also take on Push mode against fixed obstacles

Ignore - This mode that lets you place tracks anywhere, ignoring violations.

During interactive routing, if you attempt to route into an area that cannot be resolved using Push or Hug & Push modes, an indicator appears at the end of the permissible tracks so you know immediately that you are blocked (Figure 8).

Tips for Placing Tracks

Keep in mind the following points as you are placing the tracks:

- Click or press **ENTER** to place track segments up to the current cursor position. Check pattern segments represent uncommitted routing. Committed tracks are shown solid in the layer color.
- Use **CTRL + Click** at any time to use Auto-Complete the connection. Source and target pads must be on the same layer and there are no unresolvable conflicts with obstacles.
- Use **SHIFT + R** to cycle through conflict resolution modes Push, Walkaround, Hug and Push and Ignore.
- Use **SHIFT + SPACEBAR** to cycle through the various track corner modes. The styles are: any angle, 45°, 45° with arc, 90° and 90° with arc. Press **SPACEBAR** to toggle the corner direction for all but any angle mode.
- Press **END** at any time to redraw the screen.
- Use **V, F** at any time to redraw the screen to fit all objects.
- Press **PAGE UP** and **PAGE DOWN** keys at any time to zoom in or out, centered on the cursor position. Use the mouse wheel to pan left and right. Hold the **CTRL** key down to zoom in and out with the mouse-wheel.
- Press **BACKSPACE** to “unplace” the last committed track segments.
- Right-click or press **ESC** when you have finished placing a track and want to start a new one.
- You cannot accidentally connect pads that should not be wired together. Altium Designer continually monitors board connectivity and prevents you from making connection mistakes or crossing tracks.
- To delete a track segment, click it to select it. The segment's editing handles will appear (the rest of the track will be highlighted). Press the **DELETE** key to clear the selected track segment.
- Re-routing is easy – route the new track segments, when you right-click to finish, redundant track segments are automatically removed.
- When you have finished placing all the tracks on your PCB, right-click or press the **ESC** key to exit placement mode.

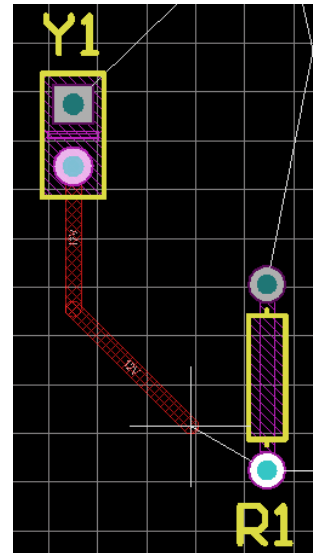

Figure 7. Cursor following streamlines the manual routing process.

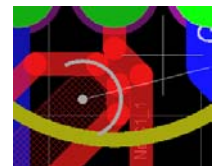

Figure 8. When Push or Hug & Push modes cannot find a path to the target pad, a blocking indicator appears.

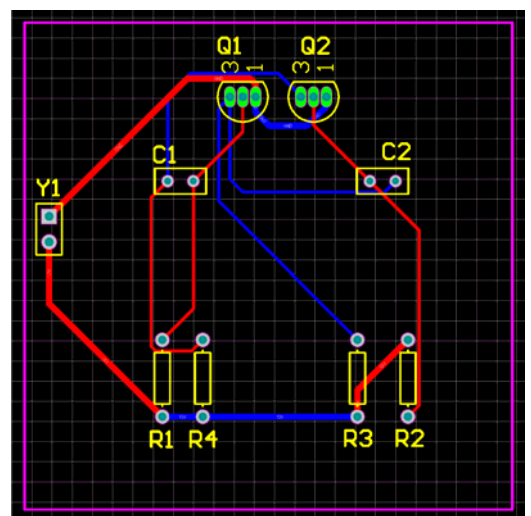



Figure 9. Manually routed board, with tracks placed on top and bottom layers.

 For more information on the various interactive routing tools, refer to the [Interactive and Differential Pair Routing](#) document.

Automatically Routing the Board

To see how easy it is to autoroute with Altium Designer, complete the following steps:

1. First, un-route the board by selecting **Tools » Un-Route » All** from the menus [shortcut: **U, A**].
2. Select **Auto Route » All**. The *Situs Routing Strategies* dialog displays. Click on **Route All**. The **Messages** panel displays the process of the autorouting.

The Situs autorouter provides results comparable with that of an experienced board designer and because it routes your board directly in the PCB editing window, there is no need to wrestle with exporting and importing route files.

3. Select **File » Save** [shortcut: **F, S**] to save your board.

Note: The tracks placed by the autorouter appear in two colors: red indicates that the track is on the top signal layer of the board and blue indicates the bottom signal layer. The layers that are used by the autorouter are specified in the **Routing Layers** design rule, which was set up in the **PCB Board Wizard**. Also notice the two power net tracks running from the connector are wider, as specified by the two Width design rules you set up.

Don't worry if the routing in your design is not exactly the same as Figure 10. The component placement will not be exactly the same, so neither will be the routing.

Because we originally defined our board as being double-sided in the **PCB Board Wizard**, you could manually route your board "double-sided" using both the top and bottom layers. To do this, un-route the board by selecting **Tools » Un-Route » All** from the menus [shortcut: **U, A**]. Start interactive routing as before, but use the * key to toggle between the layers while placing tracks. Altium Designer will automatically insert vias as necessary when you change layers.

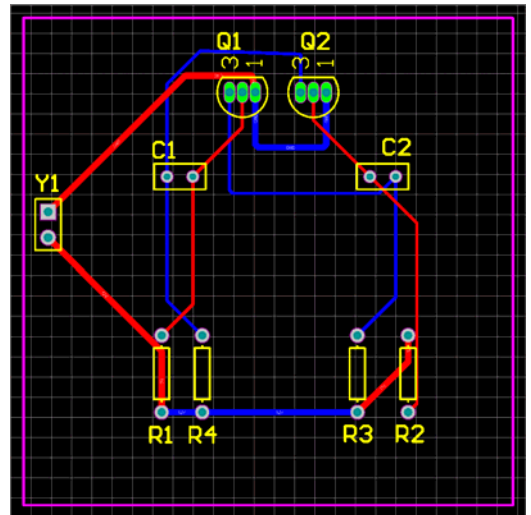

Figure 10. Fully autorouted board.

Viewing Your Board Design in 3D Mode

Now that your board design is basically complete, why not examine it in 3D? 3D mode allows you to look at your board from any direction as a full 3D model. To switch to 3D in the PCB Editor, select **View » Switch To 3D** [shortcut: **3**] or select a 3D view configuration from the list on the **PCB Standard** toolbar.



The Altium Designer 3D environment requires DirectX and associated technologies, and also using a compatible graphics card. For how to test your system and to enable Altium Designer to use DirectX, open the **PCB Editor – Display** page of the *Preferences* dialog (**Tools » Preferences**).

You can fluidly zoom the view, rotate it and even travel inside the board using the following controls:

Zooming - **CTRL** + Right-drag mouse or **CTRL** + Mouse-wheel or **PAGE UP** / **PAGE DOWN** keys.

Panning - Mouse-wheel for up/down, **SHIFT** + Mouse-wheel for left/right or right-drag mouse to pan in any direction.

Rotation - Hold down **SHIFT** to enter 3D rotation mode. This is represented on screen as a directional sphere at the cursor position (Figure 11). Rotational movement of the model is made about the center of the sphere using the following controls:

Right-drag sphere **Center Dot** with mouse for full floating view – rotate in any direction.

Right-drag sphere **Horizontal Arrow** with mouse to rotate the view about the Y-axis.

Right-drag sphere **Vertical Arrow** with mouse to rotate the view about the X-axis.

Right-drag sphere **Circle Segment** with mouse to rotate the view in the Y-plane.

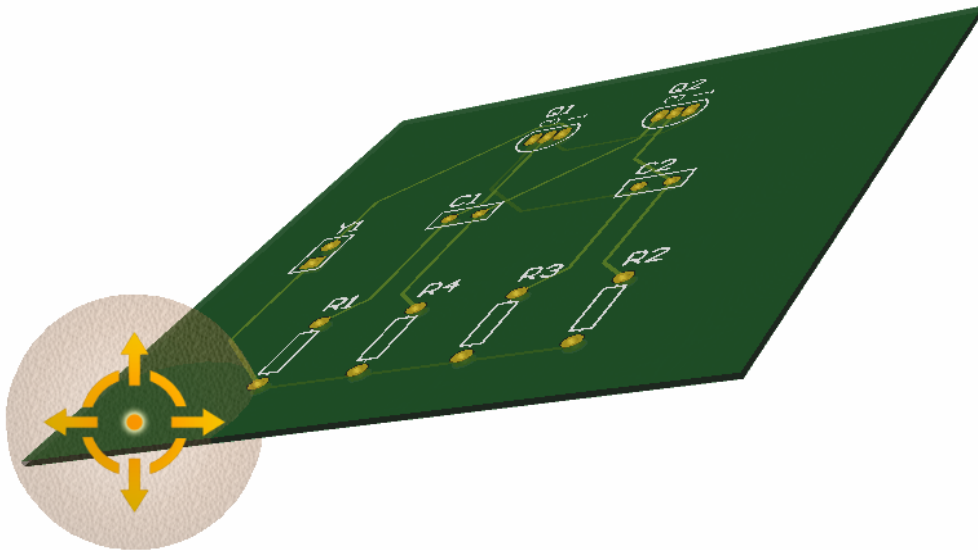

Altium Designer 3D mode requires DirectX 9.0c and Shader Model 3 or later and a suitable graphics card.

Use DirectX by enabling the Use DirectX if possible option in the PCB Editor – Display page of the Preferences dialog (Tools » Preferences).

Figure 11. The 3D view rotation sphere.

You can configure 3D workspace display options using the *View Configurations* dialog [shortcut: L]. There are options to choose various surface and workspace colors as well as vertical scaling, which is handy for examining the PCB internally. Some surfaces have an opacity setting – the greater the opacity, the less 'light' passes through the surface, which makes objects behind less visible. You can also choose to show 3D bodies or render 3D objects in their (2D) layer color.

You can import 3D STEP format models into component footprints and PCB designs and create your own 3D body objects . You can also export PCB documents in STEP and DWG/DXF formats for use in other programs. The legacy 3D viewer (**Tools » Legacy Tools » Legacy 3D View**) can import 3D objects in VRML 1.0/IGES/STEP formats and can export in IGES and STEP.

Note: At anytime in 3D mode, you can create clipboard “snapshots” of the current view, in various resolutions, using **CTRL + C**. The image is stored on the Windows clipboard in bitmap format for use in other applications.

Creating and Importing 3D Bodies for Component Footprints

So far, we have gotten to the point of final PCB verification and output. The 3D environment in Altium Designer offers an excellent facility for viewing and examining PCB assemblies in a visually rich and realistic environment.

Component footprints have the ability to store 3D bodies in them, which is used to render the component in the 3D environment. Furthermore, precise component clearance checking and even assembling entire PCBs and external, free-floating 3D objects is possible. This creates a new level of design integration with mechanical CAD packages, right within Altium Designer.

 For more information on creating 3D bodies for components, refer to the Including *Three-Dimensional Component Detail* section of the *Creating Library Components* tutorial.

 For more information on using 3D bodies for integration with MCAD applications, refer to the *Integrating MCAD Objects and PCB Designs* tutorial.

In the *Integrating MCAD Objects and PCB Designs* tutorial, the board we create in this tutorial is used, complete with 3D bodies for the components (Figure 12). The tutorial goes on to assemble that board with a mechanical housing (Figure 13). The board and components can be found in the *Examples/Tutorials/multivibrator_step* folder of your Altium Designer installation.

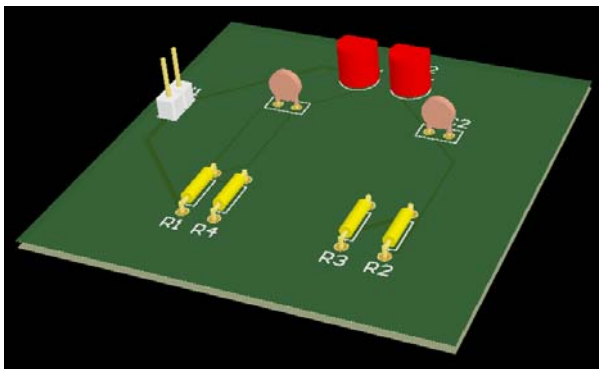

Figure 12. Multivibrator PCB, complete with component 3D bodies.

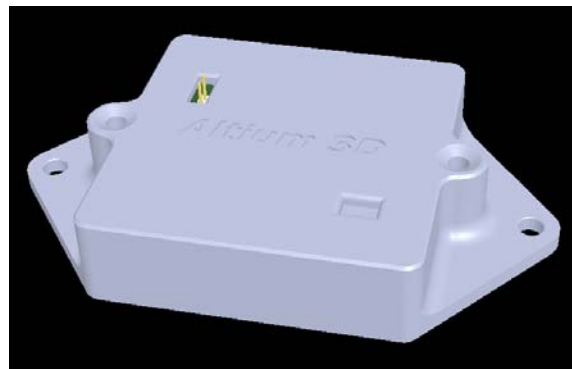

Figure 13. Multivibrator PCB fully assembled into two part housing assembly.

Verifying Your Board Design

Altium Designer provides a rules-driven environment in which to design PCBs and allows you to define many types of design rules to ensure the integrity of your board. Typically, you set up the design rules at the start of the design process and then verify that the design complies with the rules at the end of the design process.

Earlier in the tutorial we examined the routing design rules and added a new width constraint rule. We also noted that there were already a number of rules that had been created by the **PCB Board Wizard**.

To verify that the routed circuit board conforms to the design rules, we will now run a Design Rule Check (DRC):

1. Select **Design » Board Layers & Colors** [shortcut: **L**] and ensure that **Show** button next to the **DRC Error Markers** option in the **System Colors** section is enabled (ticked) so that the DRC error markers will be displayed, if any.
2. Select **Tools » Design Rule Check** [shortcut: **T, D**]. Both the online and batch DRC options are configured in the *Design Rule Checker* dialog. Click on a category, eg. **Electrical**, to see all the rules belonging to that category.
3. Leave all options at their defaults and click the **Run Design Rule Check** button. The DRC will run and the report file *Multivibrator.DRC* opens. The results will also be displayed in the **Messages** panel. Click back into the PCB document and you will see that the transistor pads are highlighted in green, indicating a design rule violation.
4. Look through the errors list in the **Messages** panel. It lists any violations that occur in the PCB design. Notice that there are four violations listed under the **Clearance Constraint** rule. The details show that the pads of transistors Q1 and Q2 violate the 13mil clearance rule.
5. Double-click on an error in the **Messages** panel to jump to its location on the PCB.

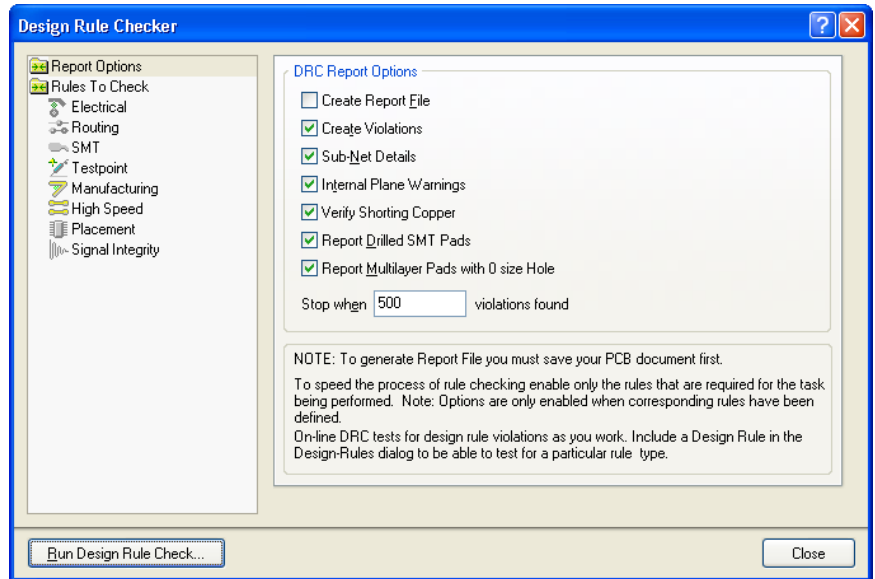

Altium Designer supports hierarchical design rules. You can set any number of rules of the same class, each with a defined scope. The rule's priority determines the rule's precedence.

Normally you would set up the clearance constraint rules before laying out your board, taking account of routing technologies and the physical properties of the devices. Let's analyze the error then review the current clearance design rules and decide how to resolve this situation.

To find out the actual clearance between the transistor pads:

1. With the PCB document active, position the cursor over the middle of one of the transistors and press the **PAGE UP** key to zoom in.
2. Select **Reports » Measure Primitives** [shortcut: **R, P**]. The cursor will change to a crosshair.
3. Position the cursor over the middle of the left pad on the transistor and click or press **ENTER**. Because the cursor is over both the pad and the track connected to it, a menu will pop up to allow you to select the desired object. Select the transistor pad from the popup menu.
4. Position the cursor over the center of the middle transistor pad and click or press **ENTER**. Once again, select the pad from the popup menu. An information box will open showing the minimum distance between the edges of the two pads is 10.63mil.
5. Close the information box, right-click or press **ESC** to exit measurement mode and then use the **V, F** shortcut to re-zoom the document.

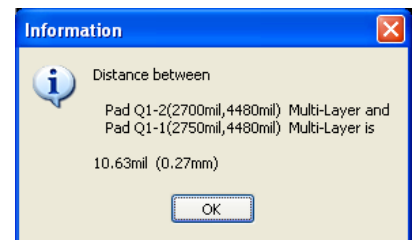

Let's look at the current clearance design rules.

1. Select **Design » Rules** from the menus [shortcut: **D, R**] to open the *PCB Rules and Constraints Editor* dialog. Double-click on the **Electrical** category to display all electrical rules in the right side of the dialog. Double-click on the **Clearance** type and then click on the **Clearance** rule to open it. The region at the bottom of the dialog will contain a single rule, specifying that

Getting Started with PCB Design

the minimum clearances for the whole board are 13mil. The clearance between the transistor pads is less than this, which is why they generate a violation when we run a DRC.

We now know the minimum distance between transistor pads is a little over 10mil, so let's set up a design rule that allows the clearance constraint to be 10mil for the transistors only.

2. Select the **Clearance** type in the Design Rules folder, right-click and select **New Rule** to add a new clearance constraint rule.
3. Click on the new Clearance rule, `Clearance_1`. In the **Constraints** section of the resulting page, set the **Minimum Clearance** to 10mil.
4. Click on **Advanced (Query)** and then click on **Query Helper** to construct the query from the Memberships Checks. Alternatively, type in the following query in the **Query** field for the first object (Figure 14):

```
HasFootprintPad('TO-92A', '*')
```

The * (asterisk) indicates 'any pad' on the footprint named TO-92A.
5. Leave the scope for the second object at ALL and click **OK**. Click **Apply** and then **OK** to close the *PCB Rules and Constraints Editor* dialog.
6. You can now re-run the DRC from the *Design Rules Checker* dialog (**Tools » Design Rule Check**) by clicking the **Run Design Rule Check** button. There should be no rule violations.
7. Save your completed PCB and the project file.

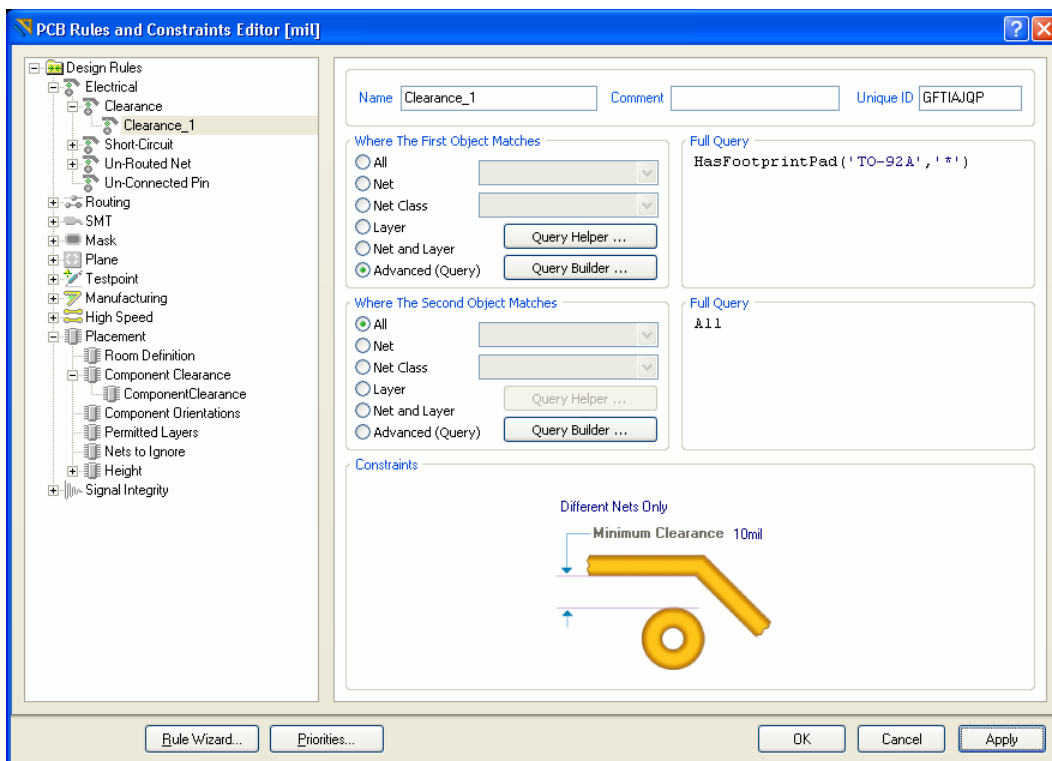

Figure 14. Using the PCB Rules and Constraints Editor dialog to create rules.

Well done! You have completed the PCB layout and are ready to produce output documentation

Output Documentation

Now that you've completed the design and layout of the PCB, you will want to produce output documentation to get the board reviewed, manufactured and assembled. These documents are generally intended for a board fabricator and, because a variety of technologies and methods exist in PCB manufacture, Altium Designer has the capability to produce numerous outputs for these purposes including:

Assembly Outputs

- Assembly Drawings - component positions and orientations for each side of the board.
- Pick and Place Files - used by robotic component placement machinery to place components onto the board.

Documentation Outputs

- Composite Drawings - the finished board assembly, including components and tracks.
- PCB 3D Prints - views of the board from a three-dimensional view perspective.
- Schematic Prints - schematic drawings used in the design.

Fabrication Outputs

- Composite Drill Drawings - drill positions and sizes (using symbols) for the board in one drawing.
- Drill Drawing/Guides - drill positions and sizes (using symbols) for the board in separate drawings.
- Final Artwork Prints - combines various fabrication outputs together as a single printable output.
- Gerber Files - creates manufacturing information in Gerber format.
- NC Drill Files - creates manufacturing information for use by numerically controlled drilling machines.
- ODB++ - creates manufacturing information in ODB++ database format.
- Power-Plane Prints - creates internal and split plane drawings.
- Solder/Paste Mask Prints - creates solder mask and paste mask drawings.
- Test Point Report - creates test point output for the design in a variety of formats.

Netlist Outputs

Netlists describe the logical connectivity between components in the design and is useful for transporting to other electronics design applications.

Report Outputs

- Bill of Materials - creates a list of parts and quantities (BOM), in various formats, required to manufacture the board.
- Component Cross Reference Report - creates a list of components, based on the schematic drawing in the design.
- Report Project Hierarchy - creates a list of source documents used in the project.
- Report Single Pin Nets - creates a report listing any nets that only have one connection.
- Simple BOM - creates text and CSV (comma separated variables) files of the BOM.

Much of the output documentation is configurable, enabling you to customize the output as necessary. As you complete more designs you may find that you often producing the same or similar output documentation for each. Altium Designer provides a mechanism called Output Job Files, using a dedicated interface - the Output Job Editor, which can be used to bundle various output documentation together and send them to various output media (direct print, PDF and file generation).

 For more information on using the OutputJob Editor, refer to the [OutputJob Editor Reference](#).

 For more information on publishing to PDF, refer to the [Publish to PDF](#) document.

Manufacturing Output Files

The final phase of the PCB design process we will cover in this tutorial is to generate Gerber and NC Drill files, and a Bill of Materials (BOM) for manufacturing purposes. We will not use the Output Job Editor here, but individual menu commands - all output documentation can be created directly from the menu system also. Note that the configurations for output documentation is stored as part of the project file.

Generating Gerber Files

Each Gerber file corresponds to one layer in the physical board – the component overlay, top signal layer, bottom signal layer, the solder masking layers and so on. It is advisable to consult with your board fabricator to confirm their requirements before supplying the output documentation required to fabricate your design.

Getting Started with PCB Design

To create the manufacturing files for the tutorial PCB:

1. Select **File » Fabrication Outputs » Gerber Files**. The *Gerber Setup* dialog displays.
2. Click the **Layers** tab, then the **Plot Layers** button and select **Used On**. Click **OK** to accept the other default settings.
3. The Gerber files are produced and the CAM Editor opens to display the files. The Gerber files are stored in the *Project Outputs* folder which is automatically created in the folder where your project files reside. Each file has the file extension added that corresponds to the layer name, eg. *Multivibrator.GTO* for Gerber Top Overlay. These are added to the **Projects** panel in the **Generated CAM Documents** folder.

Similarly, use the **File » Fabrication Outputs » NC Drill Files**

command to open the *NC Drill Setup* dialog (accepting the defaults for this exercise) to produce the NC drill data.

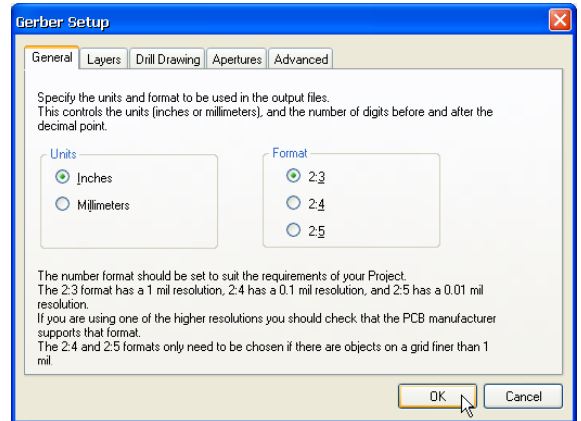

Creating a Bill of Materials

To create a Bill of Materials (BOM) for the tutorial PCB.

1. Select **Reports » Bill of Materials**. The *Bill of Materials for PCB Document* dialog displays.

If you do not want output files to automatically open when they are created, select **Project » Project Options**, click on the **Options** tab and disable the **Open outputs after compile** option.

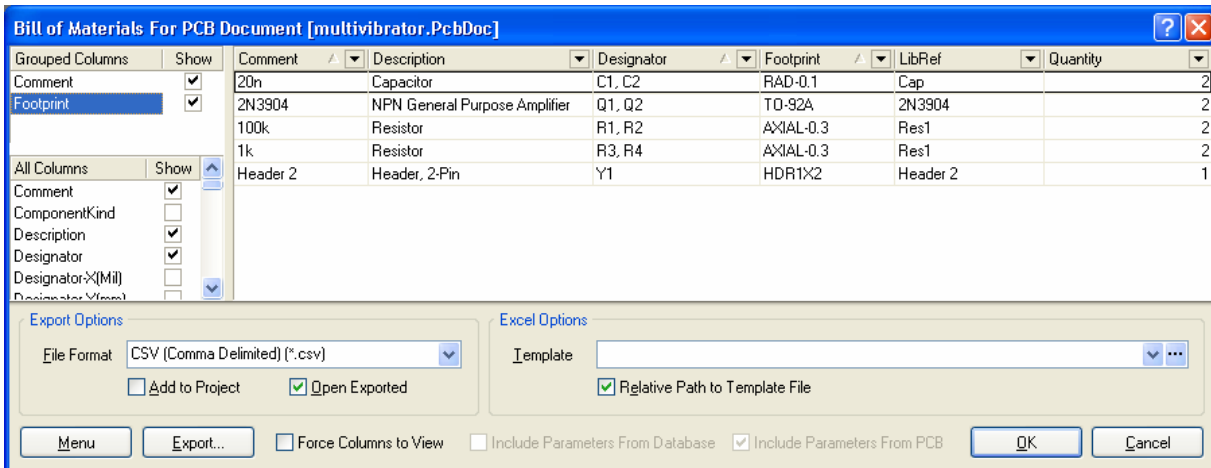

2. Use this dialog to build up your BOM. Enable the **Show** option for each column you want to include in the report.
3. Select and drag column headings from the **All Columns** list to the **Grouped Columns** list to group components by that data type in the BOM. For example, to group by *Footprint*, select **Footprint** in the **All Columns** list and drag it into the **Grouped Columns** list. The report will be sorted accordingly.
4. Enable the **Open Exported** option, select **CSV** for the **File Format**, then click the **Export** button to create and immediately open the BOM file in your CSV viewer (eg. Microsoft Excel). There are many options available for BOM and other reports, providing a high degree of flexibility in defining and organizing your reports. Close the dialogs.

Congratulations! You have completed the PCB design process.

Further Explorations

This tutorial has introduced you to just some of the powerful features of Altium Designer. We've captured a schematic, and designed and routed a PCB, but we've only just scratched the surface of the design power provided by Altium Designer. Once you start exploring Altium Designer, you will find a wealth of features to make your design life easier. To demonstrate the capabilities of the software, a number of example files are included. You can open these examples in the normal way by selecting **File » Open** from the menus and then navigating to the *Examples* folder of your Altium Designer installation. As well as the board design examples in this folder, there are a number of sub-folders with examples that demonstrate specific features of Altium Designer.

Check out the *Circuit Simulation* sub-folder to explore Altium Designer's analog and digital simulation capabilities. As well as analog examples that demonstrate various circuit designs, such as amplifiers and power supplies, there are mixed-mode examples, a mathematic function example, and an example that includes linear and non-linear dependent sources and even a vacuum tube example.

With faster logic switching and design clock speeds, the quality of the digital signals becomes increasingly important. Altium Designer includes a sophisticated signal integrity analysis tool that can accurately model and analyze your board layout. The signal integrity requirements such as impedance, overshoot, undershoot, and slope are defined as PCB design rules, and then tested during the standard design rule check.

If there are nets that you need to analyze in more detail, you can select **Tools » Signal Integrity** to pass the design to the Signal Integrity Analyzer, where you can perform reflection and cross talk simulations. The results are displayed in an oscilloscope-like waveform analyzer, where you can examine the performance and take measurements directly from the waveforms.

Thanks for participating in this introductory tutorial.

Revision History

Date	Version No.	Revision
22-Jan-2004	1.0	New product release
24-Nov-2004	1.1	Updated for DXP 2004 SP2
13-Apr-2005	1.2	Updated for Altium Designer
25-Jul-2005	1.3	Reference to <i>Board Shape & Sheets</i> tutorial renamed to <i>Preparing the Board for Design Transfer</i> . Updates for SP4.
28-Nov-2005	1.4	Updated for Altium Designer 6
31-Oct-2006	1.5	Updated for Altium Designer 6.6
17-Oct-2007	1.6	Updated with new dialog box and 3D references for Altium Designer 6.8
21-Dec-2007	1.7	Updated with 3D component body tutorial for 6.9
22-Jan-2008	1.8	Updated view configuration info, removed STEP model import info to TU0103 document (beyond scope of this tutorial) for 6.9.
1-Feb-2008	1.9	Minor typos fixed.
12-Feb-2008	2.0	Changed component body references to 3D body.
22-Feb-2008	2.1	Converted to A4.
9-Apr-2008	2.2	Updated with interactive routing and 3D body dialog box for "Summer 08".
21-May-2008	2.3	Removed component 3D body building section. Added references to TU0103 (library components tutorial) and TU0132 (MCAD integration tutorial). Amended routing and project outputs section for S08.

Software, hardware, documentation and related materials:

Copyright © 2008 Altium Limited.

The material provided with this notice is subject to various forms of national and international intellectual property protection, including but not limited to copyright protection. You have been granted a non-exclusive license to use such material for the purposes stated in the end-user license agreement governing its use. In no event shall you reverse engineer, decompile, duplicate, distribute, create derivative works from or in any way exploit the material licensed to you except as expressly permitted by the governing agreement. Failure to abide by such restrictions may result in severe civil and criminal penalties, including but not limited to fines and imprisonment. Provided, however, that you are permitted to make one archival copy of said materials for back up purposes only, which archival copy may be accessed and used only in the event that the original copy of the materials is inoperable. Altium, Altium Designer, Board Insight, DXP, Innovation Station, LiveDesign, NanoBoard, NanoTalk, OpenBus, P-CAD, SimCode, Situs, TASKING, and Topological Autorouting and their respective logos are trademarks or registered trademarks of Altium Limited or its subsidiaries. All other registered or unregistered trademarks referenced herein are the property of their respective owners and no trademark rights to the same are claimed. v8.0 31/3/08.